

# Technique Guide

## Patello-Femoral Arthroplasty

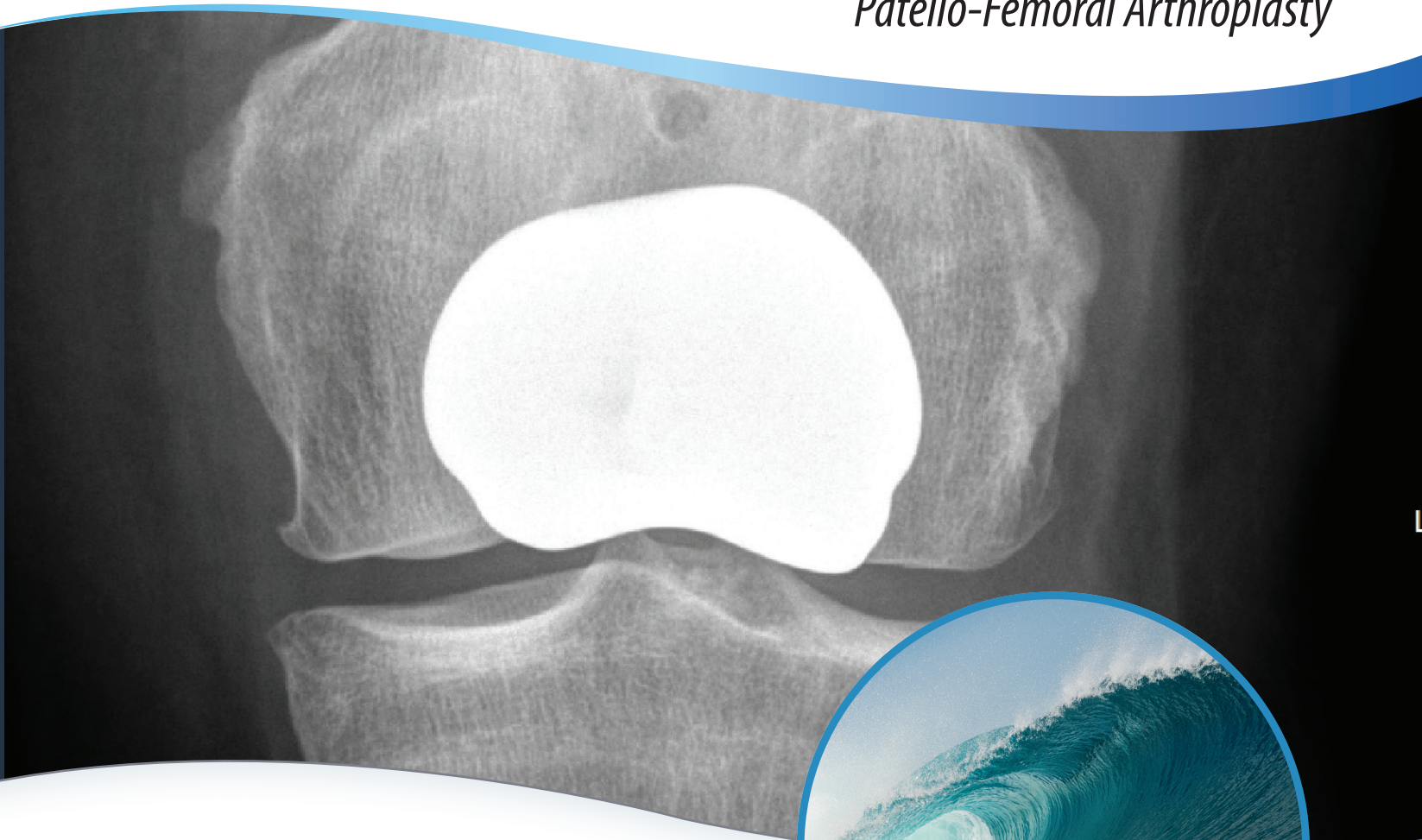

### The Patello-Femoral Arthroplasty Systems

restore the unique articular surface geometry of the Patella and the Femoral Trochlear groove.



**HemiCAP**



**PF Wave**



**Wave** Kahuna™

# Chapter Guide *Patello-Femoral Arthroplasty*

**Chapter One** (Pages 5-18)

## **HemiCAP PF Classic**

“With proper implantation of the limited trochlear resurfacing device at the site of the trochlear defect, peak pressures and force is normalized leading to decreased edge loading. This normalization of contact area, pressure, and force may translate into decreased clinical symptoms and delayed progression of chondral disease.”

*Matthew Provencher, MD. Patellofemoral Kinematics After Limited Resurfacing of the Trochlea. The Journal of Knee Surgery, 2009*

**Chapter Two** (Pages 19-30)

## **PF Wave**

“Patients treated with PFA demonstrated similar results with respect to pain relief, but showed improved function and return to activity when compared with the patients treated with TKA. Patello-femoral arthroplasty patients also experienced less blood loss, fewer complications, and shorter hospital stay following surgery. Our results indicate that PFA is a less invasive treatment option for patients with isolated PA, yielding early outcomes that compare favorably with TKA.”

*Diane L. Dahm, MD. Patellofemoral Arthroplasty Versus Total Knee Arthroplasty in Patients with Isolated Patellofemoral Osteoarthritis. The American Journal of Orthopedics, October 2010*

**Chapter Three** (Pages 19-30)

## **Wave<sup>Kahuna</sup>**

“Patients treated with PFA demonstrated similar results with respect to pain relief, but showed improved function and return to activity when compared with the patients treated with TKA. Patello-femoral arthroplasty patients also experienced less blood loss, fewer complications, and shorter hospital stay following surgery. Our results indicate that PFA is a less invasive treatment option for patients with isolated PA,





# PF Classic



## **KEY FEATURES:**

*Anatomic "Inlay" with proven threaded fixation*

*Minimal bone removal maintains future options*

*Designed for localized defects and early  
intervention*

## Description

**The HemiCAP® Patello-Femoral Arthroplasty Prosthesis** incorporates a distal femoral trochlear surface articular component that mates to a taper post via a taper interlock, and an all-polyethylene patella component. The prosthesis is intended to be used in cemented arthroplasty.

## Materials

Femoral Component:	Cobalt-Chromium Alloy (Co-Cr-Mo)
Surface Coating:	Titanium (CPTi)
Taper Post:	Titanium Alloy (Ti-6Al-4V)
Patella Component:	Ultra-High-Molecular Weight Polyethylene (UHMWPE)

## Indications

The HemiCAP® Patello-Femoral Arthroplasty Prosthesis is intended to be used in cemented arthroplasty in patients with osteoarthritis limited to the distal patello-femoral joint, patients with a history of patellar dislocation or patellar fracture, and those patients with failed previous surgery (arthroscopy, tibial tubercle elevation, lateral release, etc.) where pain, deformity or dysfunction persists.

### **Patient selection factors to be considered include:**

- 1) Need to obtain pain relief and improve function
- 2) Patient's tibio-femoral joint is substantially normal
- 3) Patient exhibits no significant mechanical axis deformity
- 4) Patient's menisci and cruciates are intact with good joint stability, and good range of motion
- 5) Patient's overall well-being is good, including the ability and willingness to follow instructions and comply with activity restrictions

## Contraindications

### **Absolute** contraindications include:

- 1) Defects that are not localized
- 2) Inflammatory degenerative joint disease, rheumatoid arthritis, infection, sepsis, or osteomyelitis
- 3) Patients that have a known sensitivity to materials typically used in orthopedic prosthetic devices or bone cements

### **Relative** contraindications include:

- 1) Uncooperative patient or patient incapable of following pre-operative and post-operative instructions
- 2) Metabolic disorders, which may impair the formation or healing of bone; osteoporosis
- 3) Infections at remote sites, which may spread to the implant site
- 4) Rapid joint destruction or bone resorption visible on roentgenogram
- 5) Chronic instability or deficient soft tissues and other support structures
- 6) Vascular or muscular insufficiency
- 7) Inadequate skin, musculotendinous or neurovascular system status

## Surgical Technique (HemiCAP® PF Classic Trochlear Component)

1. With knee at 90 degrees flexion, locate the **Drill Guide** in an anterior position to develop a working axis normal to the trochlear articular surface. Place the **Guide Pin** into a cannulated powered drill and secure at the etch marking on the **Guide Pin**. Advance the **Guide Pin** through the **Drill Guide** and into the bone making sure that it is central to the defect.

*Note: It is important to verify that the **Drill Guide** is seated on the curved surface such that all 4 points of contact are established on the articular surface. Feet on the **Drill Guide** will orient superior and inferior. A normal axis is necessary for proper implant fit.*

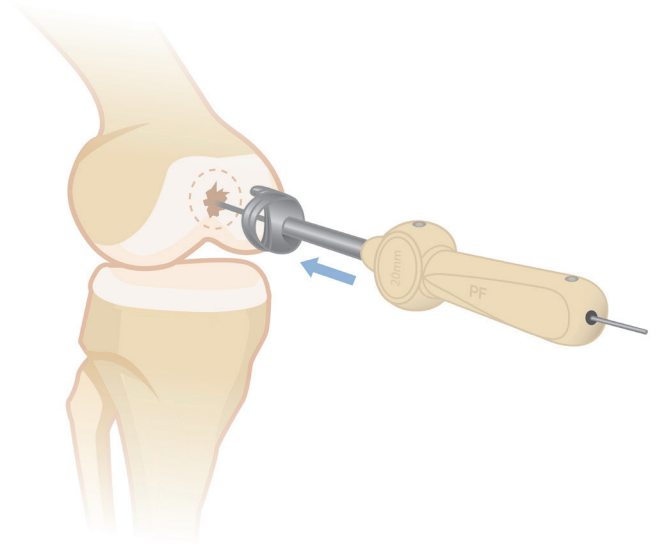

2. Place the **Step Drill** completely over the **Guide Pin**. Verify that the cannulated powered drill is not bending the **Guide Pin** and advance until the proximal shoulder of the **Step Drill** is flush to the articular surface. (Use lavage during drilling to prevent possible tissue damage from heat effects). Should the **Guide Pin** loosen, use the **Step Drill** to re-center the **Guide Pin** in the pilot hole and advance into the bone.

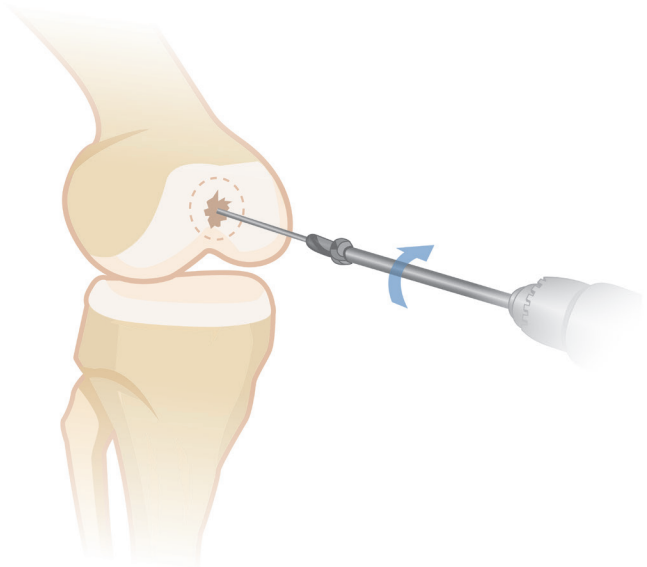

3. Advance the **Tap** into the pilot hole to the etched depth marking.

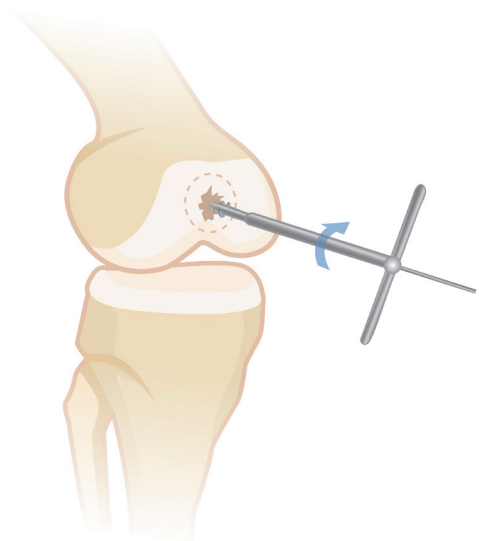

4. Place the **Hex Driver** onto the **Taper Post**. Advance the **Taper Post** until the line on the **Hex Driver** is flush with the contour of the native cartilage surface in the superior to inferior plane.

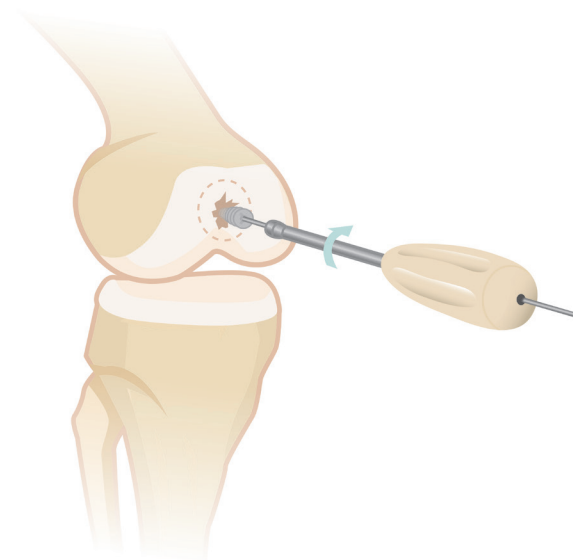

5. Clean the taper in the **Taper Post** with the **Taper Cleaner**. Place the **Trial Cap** into the **Taper Post** to confirm correct depth of the **Taper Post**. The height of the **Trial Cap** must be flush or slightly below the existing articular cartilage surface in the superior to inferior plane to avoid the **Femoral Trochlear Component** from being placed proud or above the surface of the defect. Adjust depth if needed using the **Driver** to rotate the **Taper Post** (*rotate clockwise to advance and counterclockwise to retract*). Remove the **Trial Cap**.

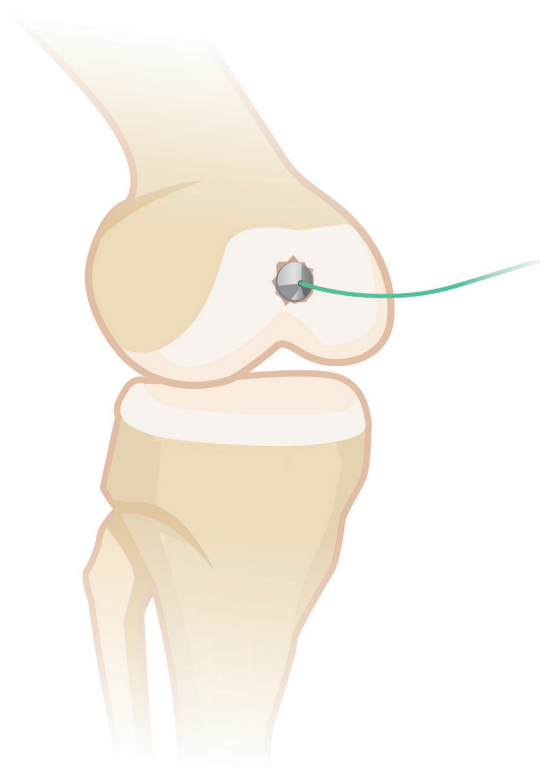
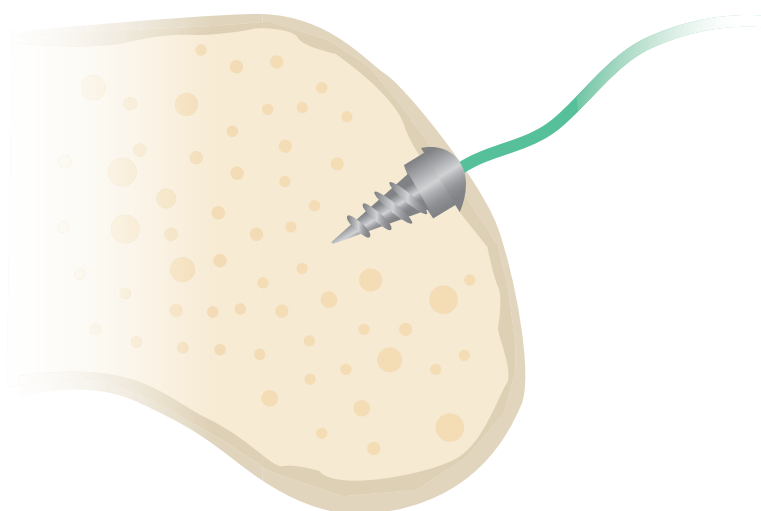

- Place the **Centering Shaft** into the taper of the **Taper Post**. Place the **Contact Probe** over the **Centering Shaft** and rotate around the shaft. Use light pressure on the **Contact Probe** to ensure proper contact with the articular surface. Read the **Contact Probe** to obtain positive (+) superior/inferior offsets, and negative (-) medial/lateral offsets. Mark each of the identified offsets on the appropriate **Sizing Card**. Use the **Sizing Card** to record the maximum superior/inferior offset and the minimum medial/lateral offset.

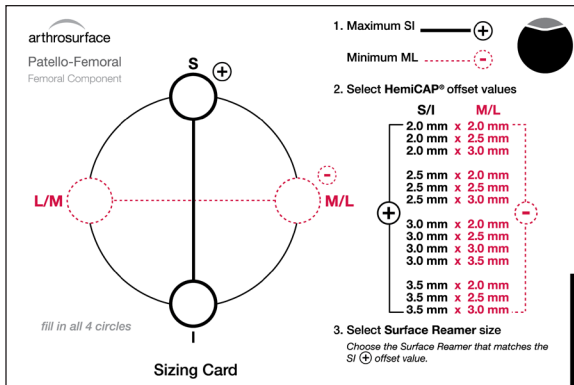

- Remove the **Centering Shaft** and replace with the **Guide Pin**. Advance the **Circular Scalpel** onto the articular surface to create a cut through the articular surface.

- Choose the appropriate **Femoral Reamer** based on the maximum superior/inferior (+) offset from the **Sizing Card**. Confirm selection by matching the color code on the **Femoral Component** package with the colored band on the **Femoral Reamer** shaft. Advance the **Femoral Reamer** over the **Guide Pin** until it contacts the top surface on the **Taper Post**. (Use lavage during drilling to prevent possible tissue damage from heat effects). Make sure not to bend the **Guide Pin** during drilling as it may result in malalignment of the **Femoral Trochlear Component**.

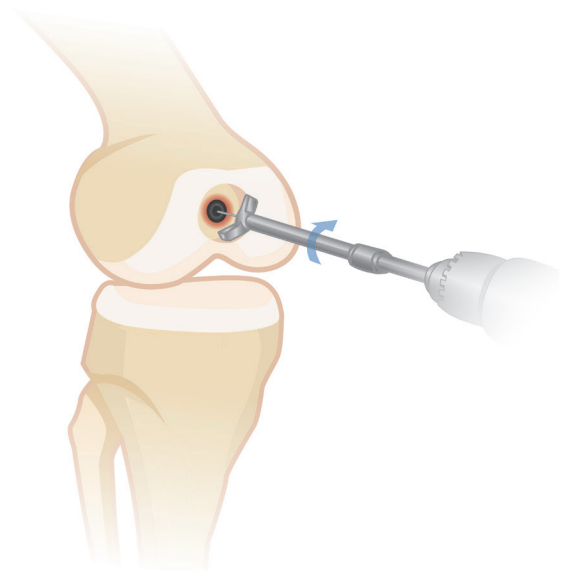
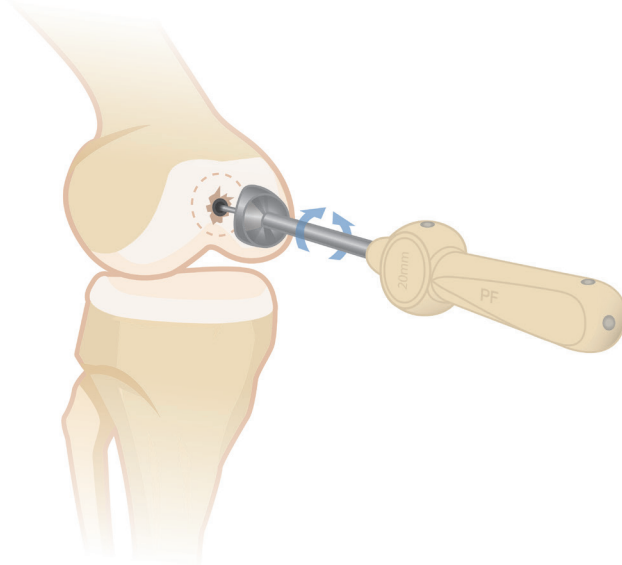
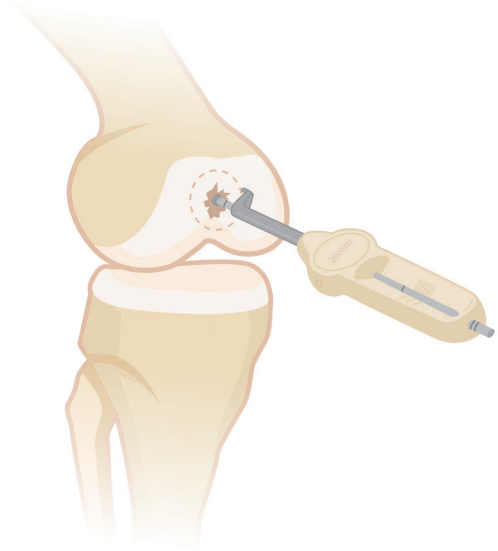

9. Clean the taper in the **Taper Post** with the **Taper Cleaner** and remove any debris from surrounding implant bed.

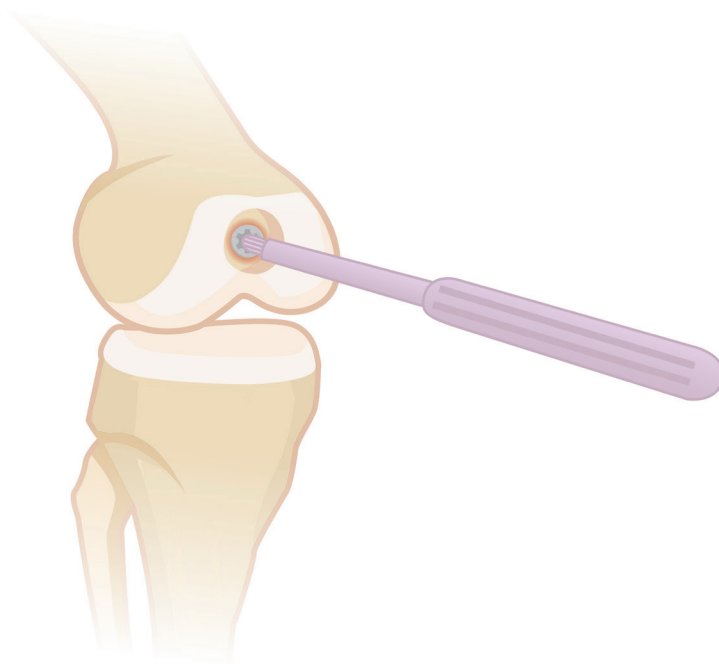

10. Place the **Sizing Trial** into the defect that matches the offset profile of the chosen **Femoral Trochlear Component**. Confirm the fit of the **Sizing Trial** so that all margins are congruent or slightly recessed to the edge of the surrounding articular surface.

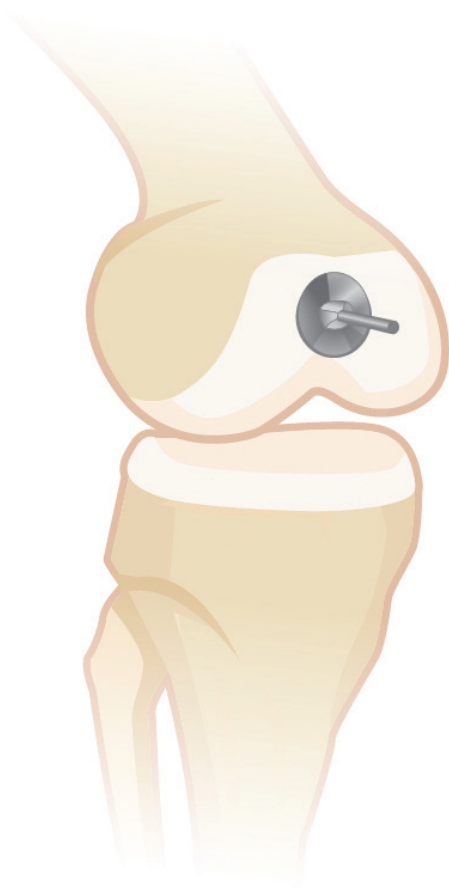
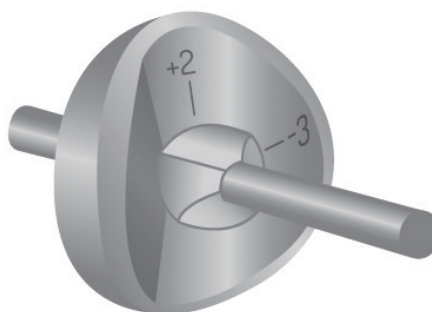



**NOTE:** Prepare and implant the **Patella Component** (p. 12) prior to the final placement of the **Femoral Trochlear Component**.



11. Prior to placing the **Femoral Trochlear Component** on the **Implant Holder**, make sure that sufficient suction is present to hold the device on the distal suction cup. Orient the etch marks on the back of the **Femoral Trochlear Component** with the etch mark on the handle of the **Implant Holder**. Apply a small amount of low-viscosity bone cement onto the underside of the **Trochlear Component**. Insert into the taper of the **Taper Post**.

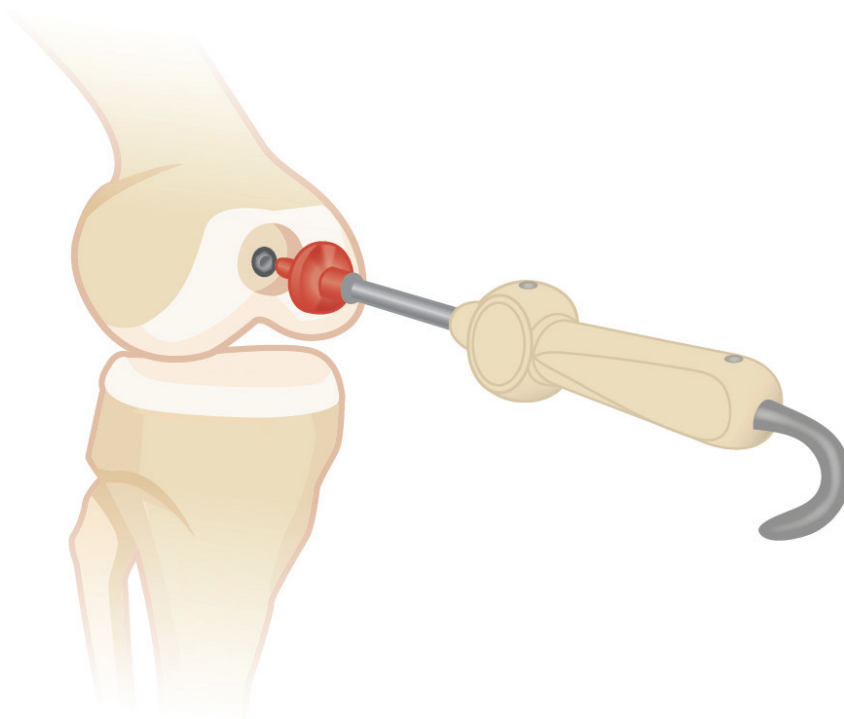

12. Firmly mallet the **Impactor** until the **Femoral Trochlear Component** is completely seated.

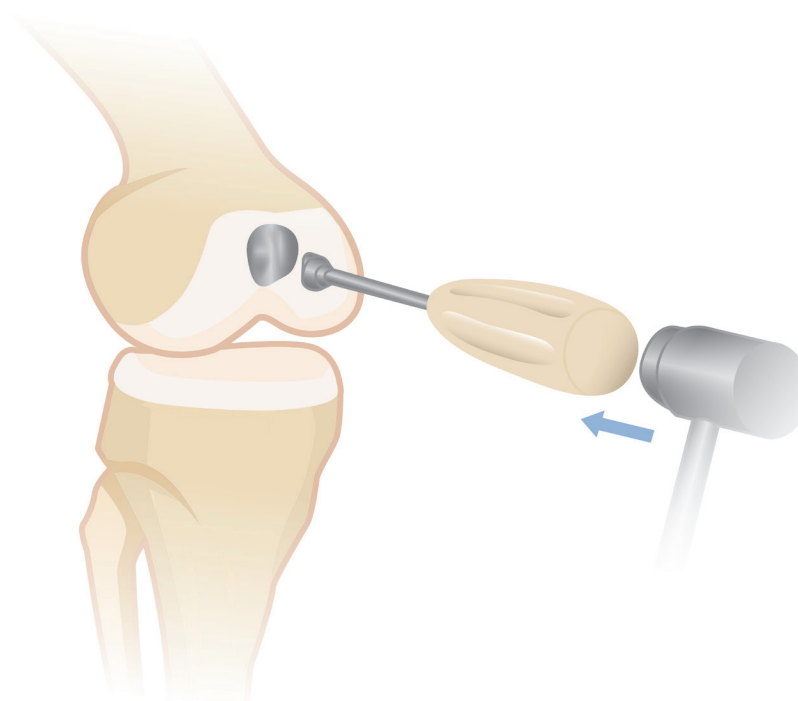

## Surgical Technique (HemiCAP® PF Classic Patella Component)

1. Confirm that the patella's anterior to posterior thickness will accept the **Patella Component** (typically a 6.5mm reaming depth). With the knee at 90 degrees flexion, locate the **Alignment Guide** so that the pin fits into the **Taper Post**. While observing the range of motion, identify target placement of the **Patella Component** using the pointer on the **Alignment Guide** to transfer the **Taper Post's** central axis. (Typically 20 to 30 degrees of flexion). Use slight pressure against the patella so that the pointer on the **Alignment Guide** creates an indentation on the patella surface.

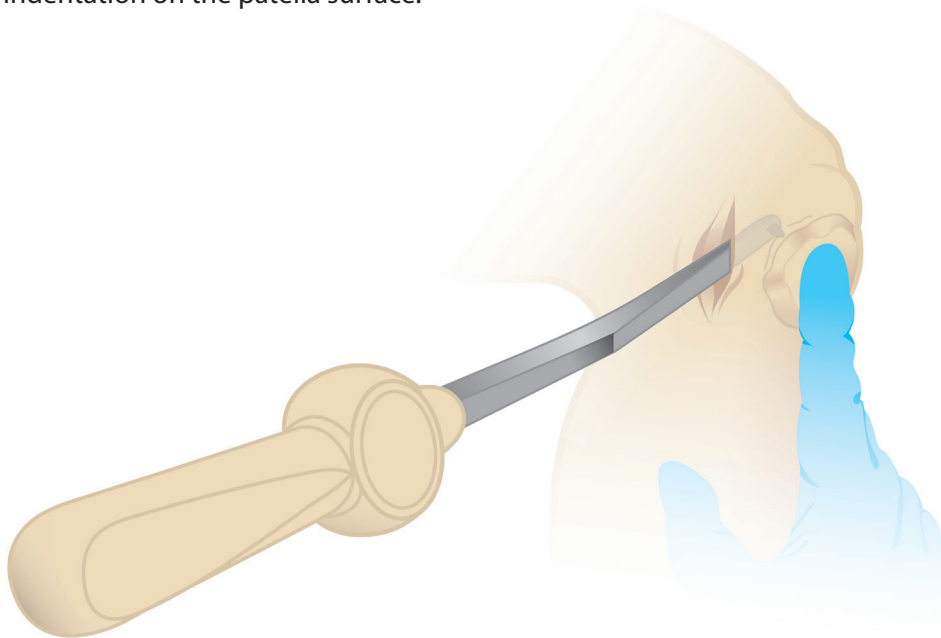
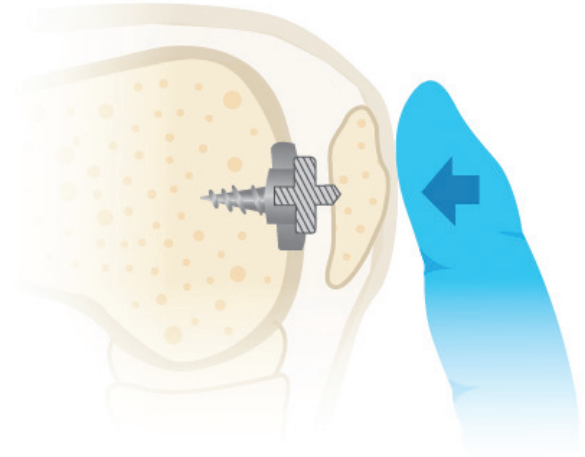

2. Place the **Drill Guide** so that its central axis passes through the **Alignment Guide** indentation created on the patella surface. Drill the **Guide Pin** through until it engages the opposite cortex of the patella.

*Note: It is important to verify that the **Drill Guide** is seated on the curved surface such that all 4 points of contact are established on the articular surface. Feet on the **Drill Guide** will typically orient medial and lateral. A normal axis is necessary for proper implant fit.*

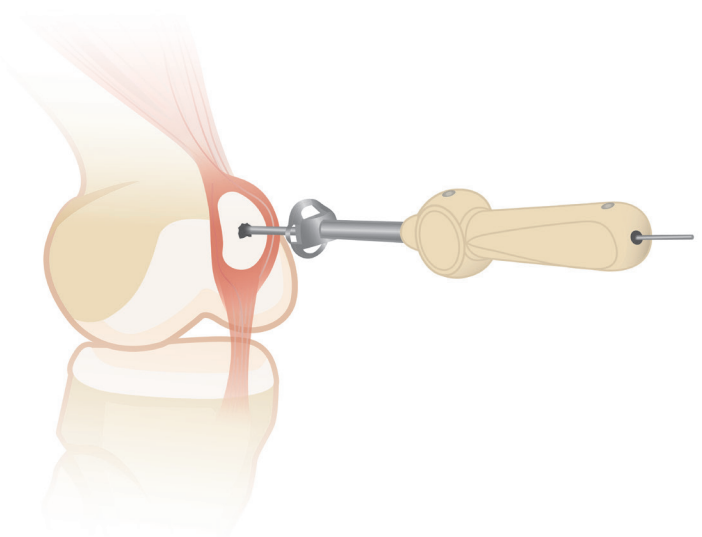

3. Remove the **Drill Guide**. Advance the **Circular Scalpel** onto the articular surface to create a cut through the articular surface. Place the **Step Drill** over the **Guide Pin**. Verify that the cannulated powered drill is not bending the **Guide Pin** and advance until the distal shoulder of the **Step Drill** is flush to the articular surface. *(Use lavage during drilling to prevent possible tissue damage from heat effects)*. Should the **Guide Pin** loosen, use the **Step Drill** to re-center the **Guide Pin** in the pilot hole and advance into the bone.

14mm Patella Drill Depth

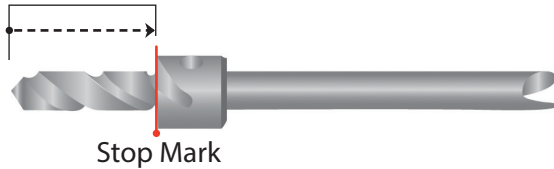

4. Using a cannulated powered drill, advance the **Patella Centering Shaft** over the **Guide Pin** until it reaches the distal laser depth marking.

5. Place the **Contact Probe** over the **Patella Centering Shaft**. Read the **Contact Probe** to take medial, lateral, superior, and inferior offsets and mark them onto the appropriate **Sizing Card**.

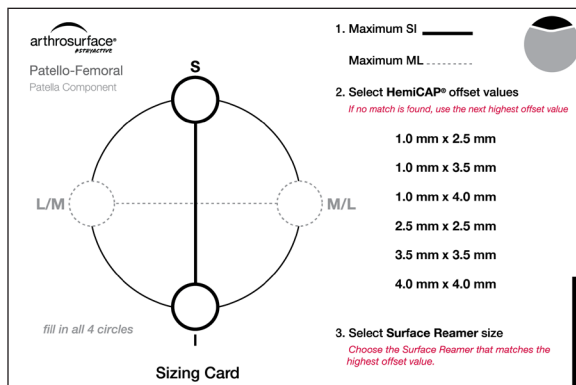
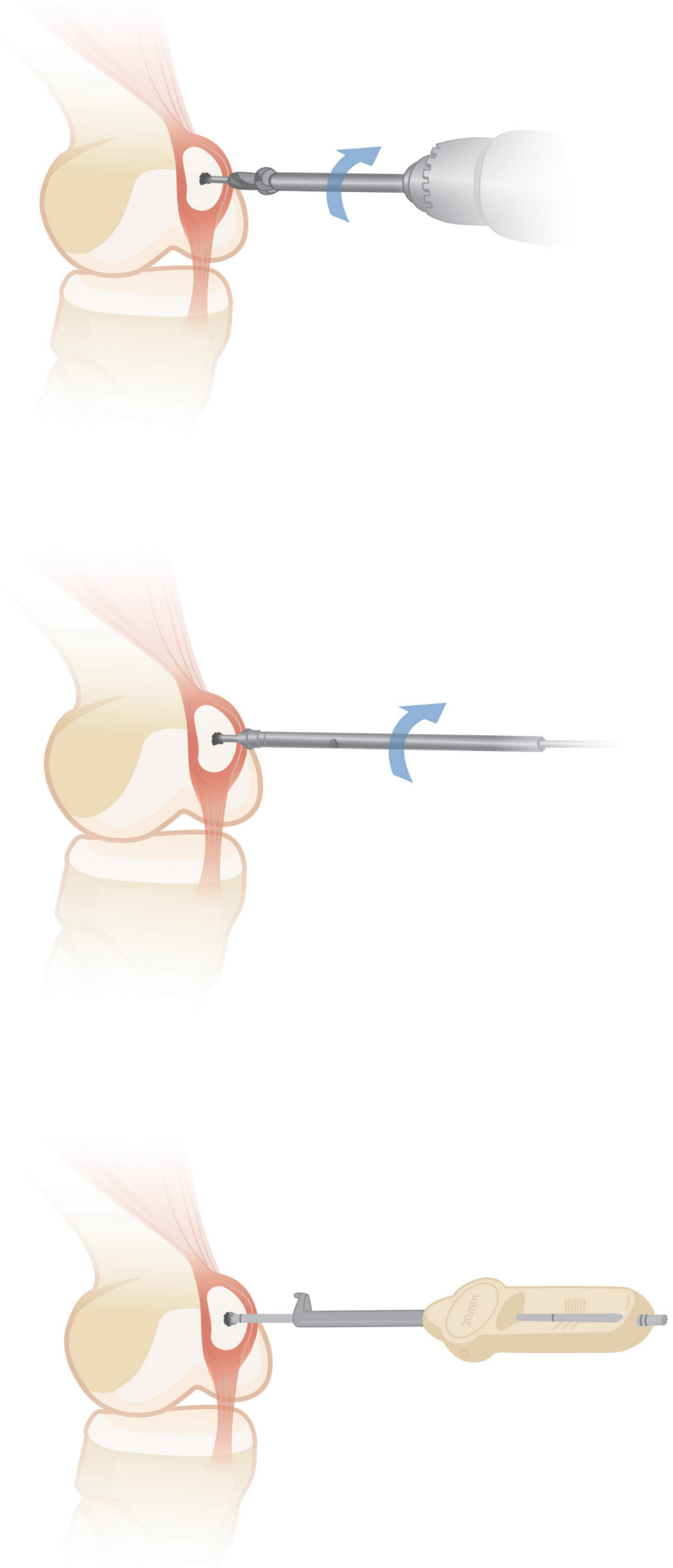

6. Select the 2.5mm **Patella Reamer**. Advance the **Patella Reamer** over the **Patella Centering Shaft** until it makes contact with the blade stop.

*Note: Use lavage during drilling to prevent possible tissue damage from heat effect.*

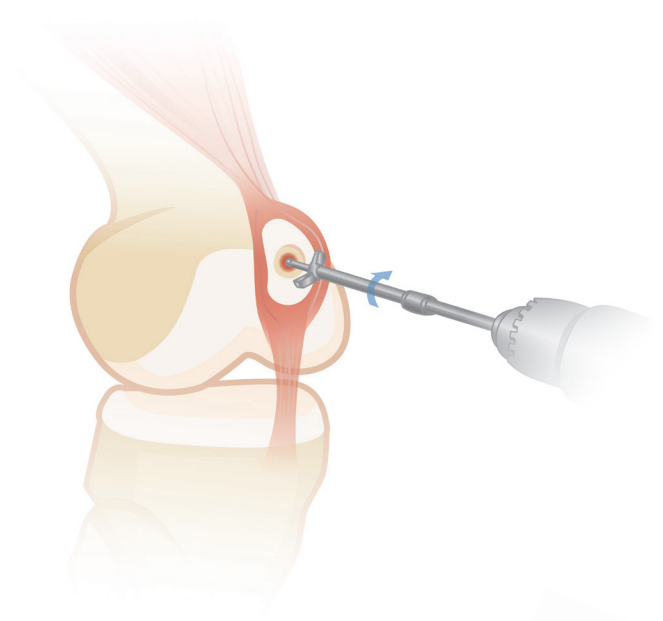

7. Load a loop of the #2 suture through the appropriately sized **Patella Sizing Trial** and place into the prepared area. Confirm the fit of the **Patella Sizing Trial** so that all margins are congruent or slightly recessed to the edge of the surrounding articular surface.

*Note: (If using an **Anatomic Patella Component**) After using a 2.5mm **Patella Reamer**, place a 1.0 x 2.5 **Patella Sizing Trial** and confirm fit of medial and lateral margins. Once M/L margins are a congruent fit to the medial/lateral cartilage, select the trial that best fits the superior/inferior margins without additional reaming. If proud at the M/L margin, drill with the next sized **Patella Reamer** and repeat trialing to fit.*

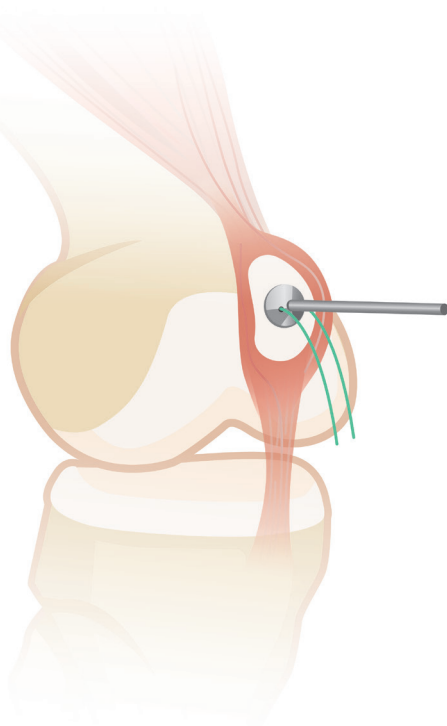
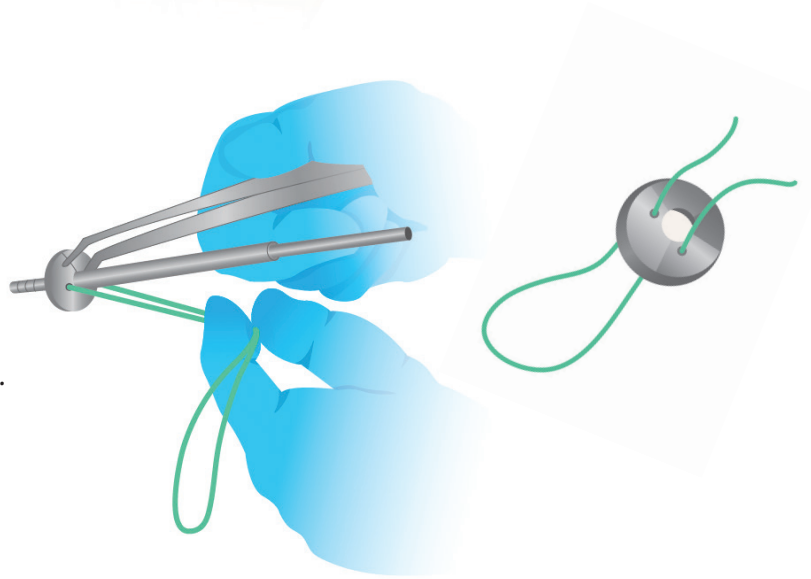

8. Apply a small amount of low-viscosity bone cement onto the underside of the **Patella Component** and quickly place into position. Prior to placing the **Patella Component** on the **Implant Holder**, make sure that sufficient suction is present to hold the device on the distal suction cup. Align the **Patella Component** on the **Implant Holder**.

*Note: When using the **Anatomic Patella Component**, make sure to align the superior and inferior orientation divots with the superior and inferior poles of the patella.*

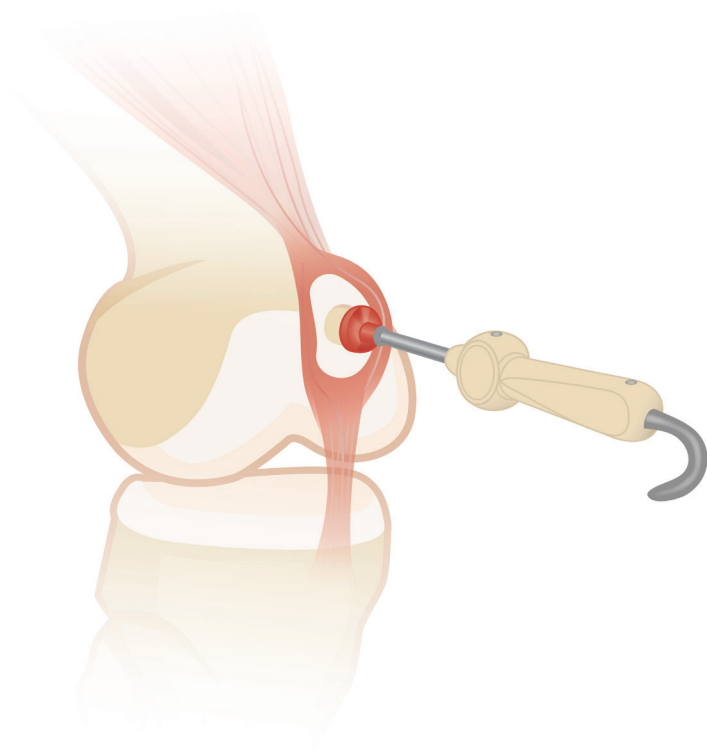
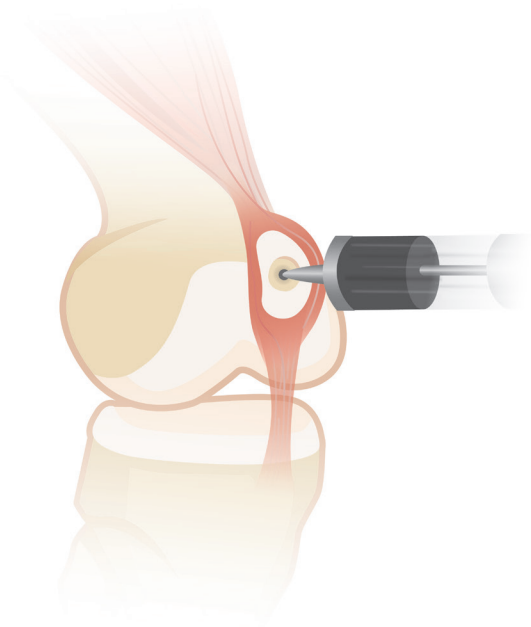

9. Using the **Patella Clamp**, place the **Anatomic OR Button Contoured Swivel Pin** against the **Patella Component** and the anterior patella surface. Tighten the **Patella Clamp** until the **Patella Component** is firmly seated in the prepared socket. Leave the **Patella Clamp** in place while the bone cement adequately cures. Remove the **Patella Clamp** and clean out any remaining exposed cement.

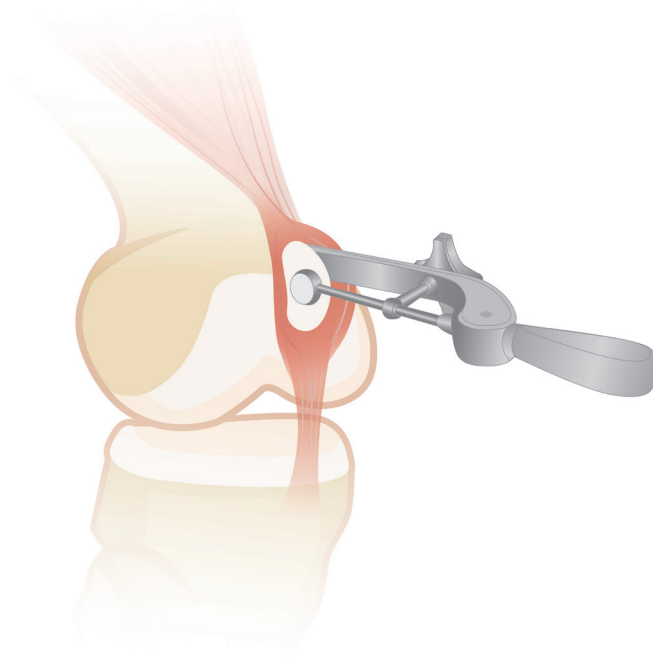

10. Implantation of the **Patella Component** is complete.

**NOTE:** Complete implantation of **Femoral Trochlear Component** (p. 11)

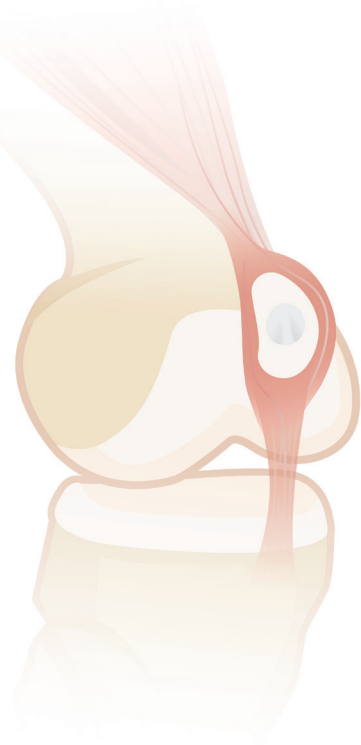
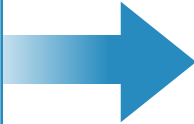

11. Once implantation of the **Femoral** and **Patella Components** are complete, perform a trial range of motion. Remove or debride any loose tissues if necessary. Close utilizing accepted practices.

## System Catalog

### Instrumentation System

7000-2000	Instrument Kit, Patello-Femoral
7000-2005	Revision Kit, Patello-Femoral
7007-1305	2.0mm Guide Pin (5 Pk)

### Articular Component, Trochlear

	⊕ S/I	⊖ M/L
P202-2020	2.0mm x 2.0mm Offset	
P202-2025	2.0mm x 2.5mm Offset	
P202-2030	2.0mm x 3.0mm Offset	
P202-2520	2.5mm x 2.0mm Offset	
P202-2525	2.5mm x 2.5mm Offset	
P202-2530	2.5mm x 3.0mm Offset	
P202-3020	3.0mm x 2.0mm Offset	
P202-3025	3.0mm x 2.5mm Offset	
P202-3030	3.0mm x 3.0mm Offset	
P202-3035	3.0mm x 3.5mm Offset	
P202-3520	3.5mm x 2.0mm Offset	
P202-3525	3.5mm x 2.5mm Offset	
P202-3530	3.5mm x 3.0mm Offset	

### Articular Component, Patella

<i>Anatomic Patellas</i>	
P205-1025	1.0mm x 2.5mm Offset
P205-1035	1.0mm x 3.5mm Offset
P205-1040	1.0mm x 4.0mm Offset

<i>Button Patellas</i>	
P206-0025	2.5mm x 2.5mm Offset
P206-0035	3.5mm x 3.5mm Offset
P206-0040	4.0mm x 4.0mm Offset

### Taper Post

P085-0017	Taper Post, 8.5mm x 17mm
-----------	--------------------------

# Instrumentation (HemiCAP® PF Classic)

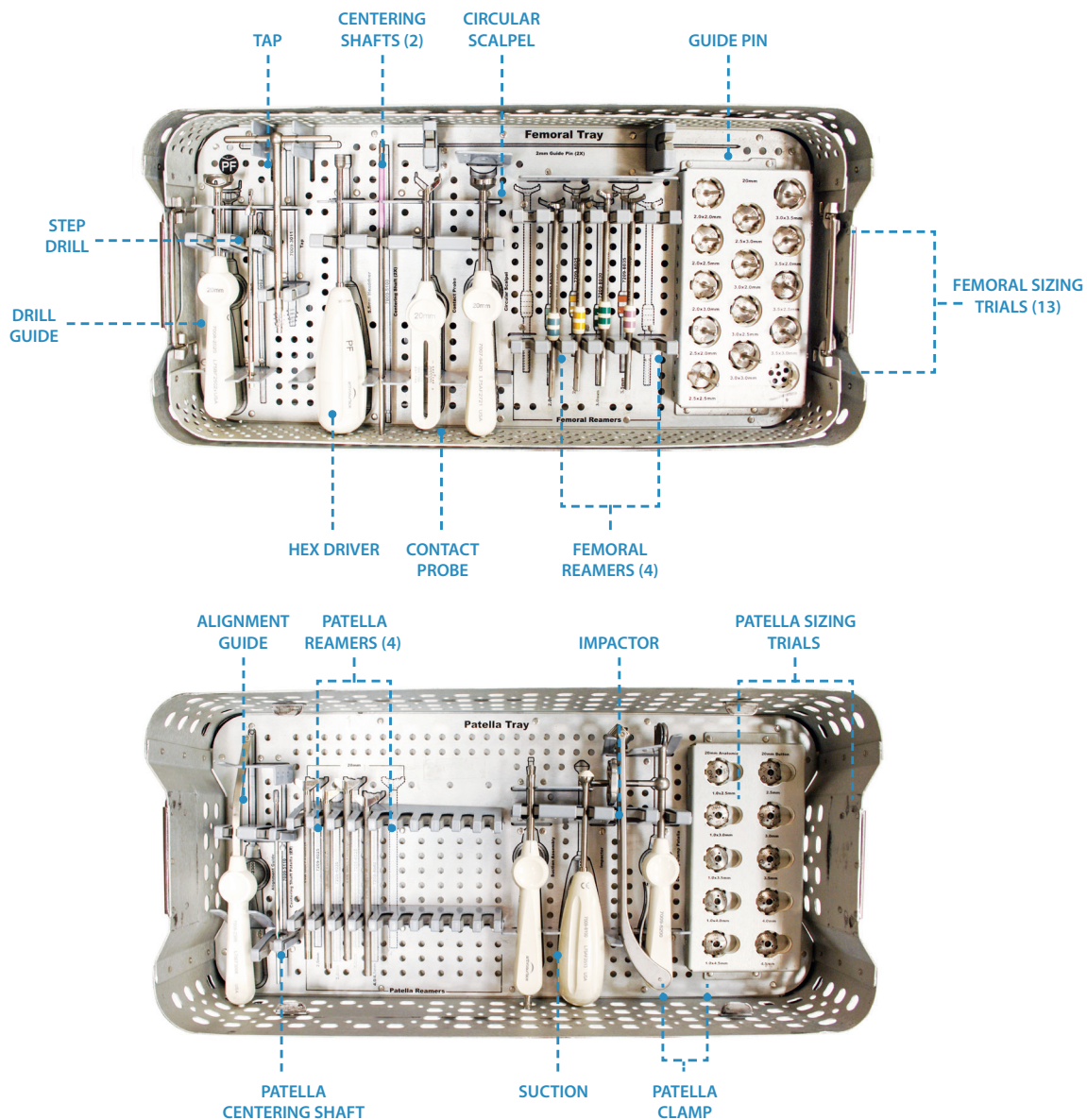

# Sizing Cards (HemiCAP® PF Classic)

arthrosurface  
Patello-Femoral  
Femoral Component

1. Maximum SI  +

Minimum ML  -

2. Select HemiCAP® offset values

S/I	M/L
2.0 mm x 2.0 mm	2.0 mm x 2.0 mm
2.0 mm x 2.5 mm	2.0 mm x 2.5 mm
2.0 mm x 3.0 mm	2.0 mm x 3.0 mm
2.5 mm x 2.0 mm	2.5 mm x 2.0 mm
2.5 mm x 2.5 mm	2.5 mm x 2.5 mm
2.5 mm x 3.0 mm	2.5 mm x 3.0 mm
3.0 mm x 2.0 mm	3.0 mm x 2.0 mm
3.0 mm x 2.5 mm	3.0 mm x 2.5 mm
3.0 mm x 3.0 mm	3.0 mm x 3.0 mm
3.0 mm x 3.5 mm	3.0 mm x 3.5 mm
3.5 mm x 2.0 mm	3.5 mm x 2.0 mm
3.5 mm x 2.5 mm	3.5 mm x 2.5 mm
3.5 mm x 3.0 mm	3.5 mm x 3.0 mm

3. Select Surface Reamer size  
Choose the Surface Reamer that matches the SI + offset value.

fill in all 4 circles

Sizing Card

FIN 2001-1221 Rev D

arthrosurface  
Patello-Femoral  
Patella Component

1. Maximum SI

Maximum ML

2. Select HemiCAP® offset values  
*If no match is found, use the next highest offset value*

- 1.0 mm x 2.5 mm
- 1.0 mm x 3.5 mm
- 1.0 mm x 4.0 mm
- 2.5 mm x 2.5 mm
- 3.5 mm x 3.5 mm
- 4.0 mm x 4.0 mm

3. Select Surface Reamer size  
*Choose the Surface Reamer that matches the highest offset value.*

fill in all 4 circles

Sizing Card

FIN 2001-1220 Rev C

PF Wave™  
**PF Wave**



**KEY FEATURES:**

*Minimal bone removal maintains future options*

*Multiple inlay trochlea and patella implants  
provide an anatomic articulation*

*Reproducible milling jigs for precise fit*



## Description

The PF Wave™ Arthroplasty Prosthesis incorporates a distal femoral trochlear surface articular component that mates to a taper post via a taper interlock, and an all-polyethylene patella component. The prosthesis is intended to be used in cemented arthroplasty.

## Materials

Femoral Component:	Cobalt-Chromium Alloy (Co-Cr-Mo)
Surface Coating:	Titanium (CPTi)
Taper Post:	Titanium Alloy (Ti-6Al-4V)
Patella Component:	Ultra-High-Molecular Weight Polyethylene (UHMWPE)

## Indications

The PF Wave™ Arthroplasty Prosthesis is intended to be used in cemented arthroplasty in patients with osteoarthritis limited to the distal patello-femoral joint, patients with a history of patellar dislocation or patellar fracture, and those patients with failed previous surgery (arthroscopy, tibial tubercle elevation, lateral release, etc.) where pain, deformity or dysfunction persists.

### Patient selection factors to be considered include:

- 1) Need to obtain pain relief and improve function
- 2) Patient's tibio-femoral joint is substantially normal
- 3) Patient exhibits no significant mechanical axis deformity
- 4) Patient's menisci and cruciates are intact with good joint stability, and good range of motion
- 5) Patient's overall well-being is good, including the ability and willingness to follow instructions and comply with activity restrictions

## Contraindications

### Absolute contraindications include:

- 1) Defects that are not localized
- 2) Inflammatory degenerative joint disease, rheumatoid arthritis, infection, sepsis, or osteomyelitis
- 3) Patients that have a known sensitivity to materials typically used in orthopedic prosthetic devices or bone cements

### Relative contraindications include:

- 1) Uncooperative patient or patient incapable of following pre-operative and post-operative instructions
- 2) Metabolic disorders, which may impair the formation or healing of bone; osteoporosis.
- 3) Infections at remote sites, which may spread to the implant site
- 4) Rapid joint destruction or bone resorption visible on roentgenogram
- 5) Chronic instability or deficient soft tissues and other support structures
- 6) Vascular or muscular insufficiency
- 7) Inadequate skin, musculotendinous or neurovascular system status

# Surgical Technique (PF Wave™ Trochlear Component)

1. With knee in extension, locate the **Offset Drill Guide** in an anterior position to develop a working axis normal to the central trochlear articular surface. Align the "L" laser mark to the lateral aspect of the femur. Place the **2.5mm Guide Pin** into a cannulated powered drill and secure at the etch marking on the **Guide Pin**. Advance the **Guide Pin** into the bone.

*Note: It is important to verify that the **Drill Guide** is seated on the curved surface such that all 4 points of contact are established on the articular surface. A normal axis is necessary for proper implant fit.*

2. Place the yellow **Offset Sleeve** over the **Guide Pin** so the foot of the **Offset Sleeve** is touching the deepest (medial) portion at the center of the trochlea.

3. Read the **Contact Probe** to obtain positive (+) superior/inferior offsets and negative (-) medial/lateral offsets. Alternatively, the **Sizing Templates** can be utilized. Mark each of the identified offsets on the appropriate **Sizing Card**. Use the **Sizing Card** to record the average superior/inferior offset and the average medial/lateral offset.

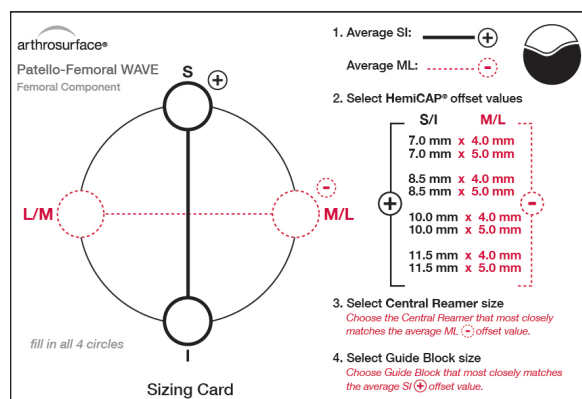
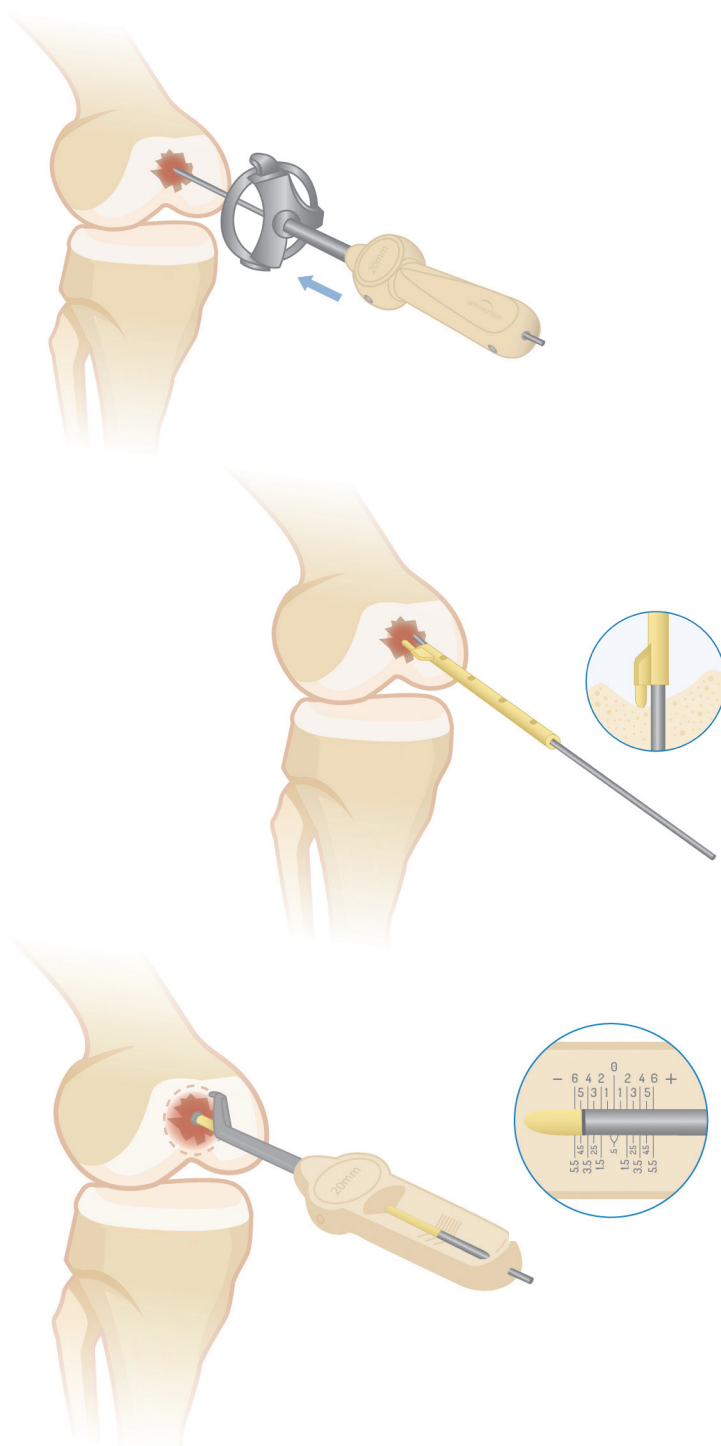

S/I Template

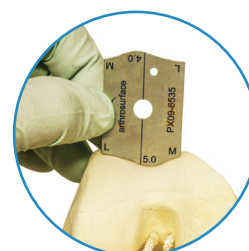

M/L Template

4. Select the **35mm Central Reamer** based on the medial/lateral offset (either 4 or 5mm) and advance it over the **Guide Pin** until the etched mark on the side of the **Central Reamer** is flush with the medial/lateral facets.

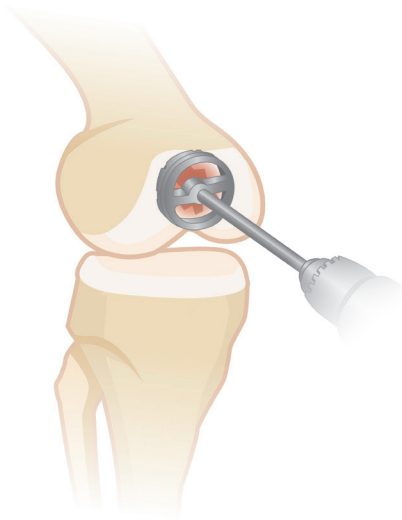

5. Select the **Guide Block** that corresponds with the offset from the superior/inferior mapping point and place onto the trochlear groove. Align the **Guide Block** per medial and lateral indicator laser marks. Secure the **Guide Block** onto the femur using **Guide Pins**. In knees with a dysplastic or flattened trochlea, the **Guide Block** may not sit flush to the reamed area. Use an osteotome to create slots in the bone to accept the proximal and distal feet of the **Guide Block**. Creating these slots will allow the **Guide Block** to sit flush to the reamed area. Advance the **Circular Scalpel** into the superior/inferior bores of the **Guide Block** and onto the articular surface using a twisting motion to create a cut through the articular surface.

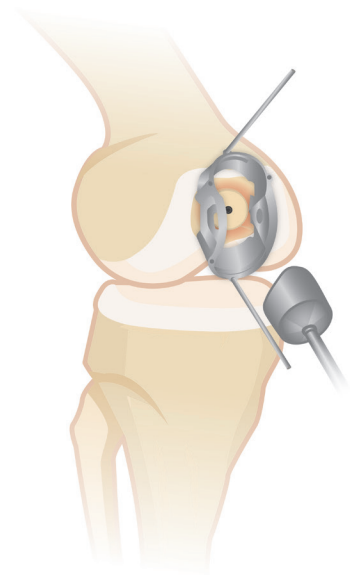

6. Assemble the **Outer Reamer** into the **Guide Bushing**. Secure the **Guide Bushing** into the superior **Guide Block** bore. Advance the **Outer Reamer** into the bone until the depth mark on the reamer shaft is reached. Remove assembly and repeat reaming through the inferior **Guide Block** bore. It is critical to keep the **Guide Block** stable during reaming. Repeat for the **Cutter**.

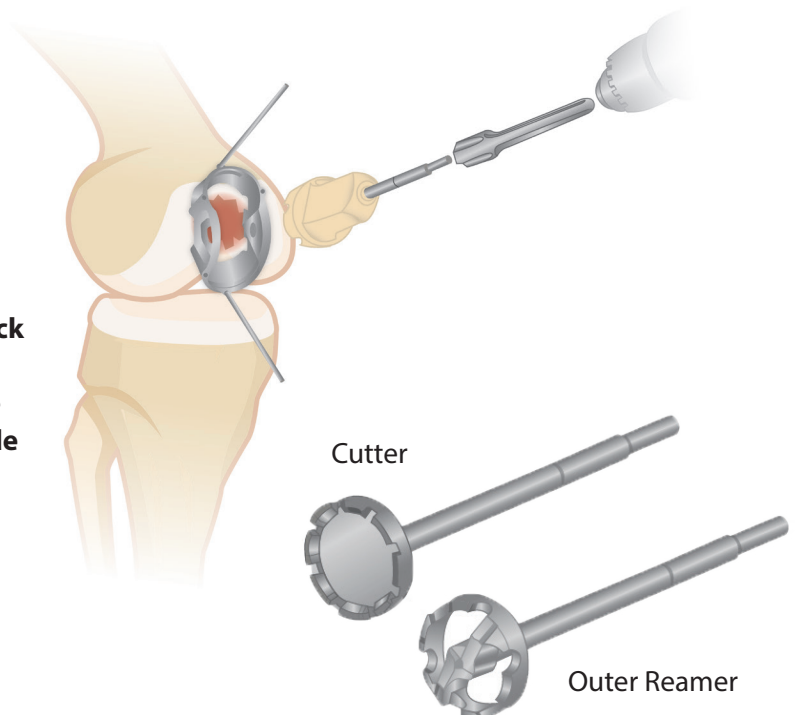

7. Assemble the **Trial Handle** onto the **Sizing Trial** and place the **Sizing Trial** into the prepared site that matches the offset profile from the **Sizing Card**. Confirm the fit of the **Sizing Trial** so that all margins are congruent or recessed to the edge of the surrounding articular surface. Trim the transition areas between reamed surfaces to ensure the **Sizing Trial** is fully seated.

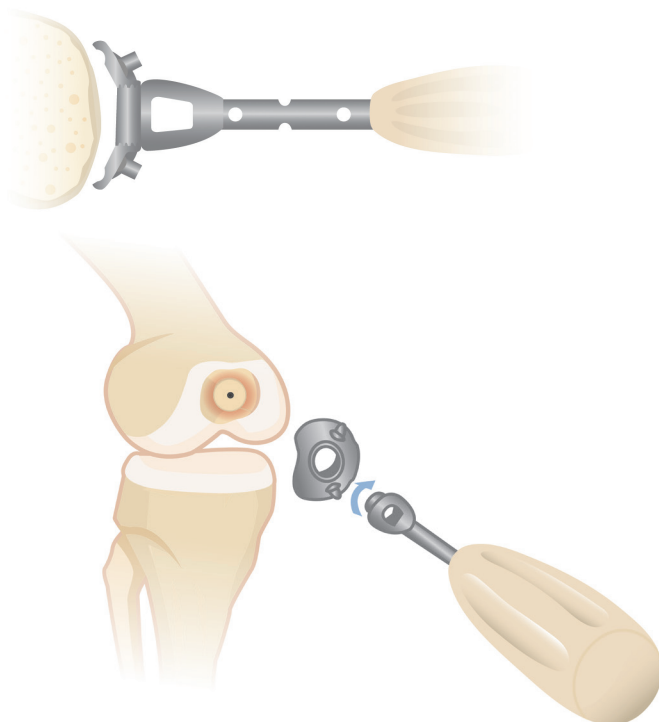

8. Fix the **Sizing Trial** in place and insert the **Pilot Drill** through the center of the **Trial Handle** and advance to the laser mark indicated on the **Pilot Drill**. Leave the **Pilot Drill** in place and remove the **Trial Handle** from the **Sizing Trial**.

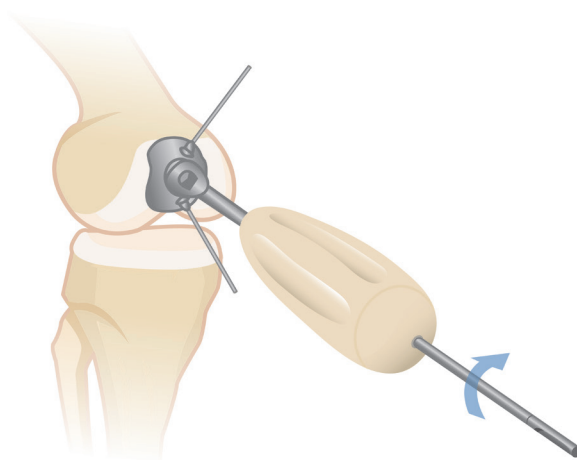

9. Advance the **Step Drill** over the **Pilot Drill** until it bottoms out on the back of the **Pilot Drill**. Remove the **Step Drill**.

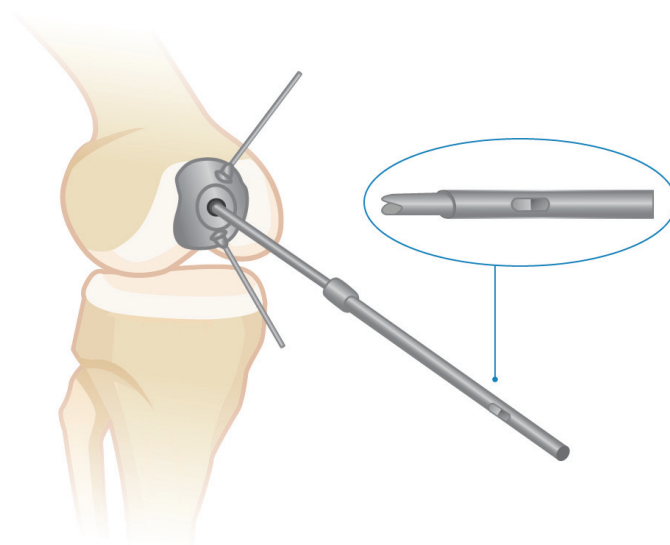

10. Advance the **Tap** over the **Pilot Drill** so the end stops when the **Pilot Drill** is flush to the back of the cannulation in the **Tap**. Remove the **Tap** and **Pilot Drill**.

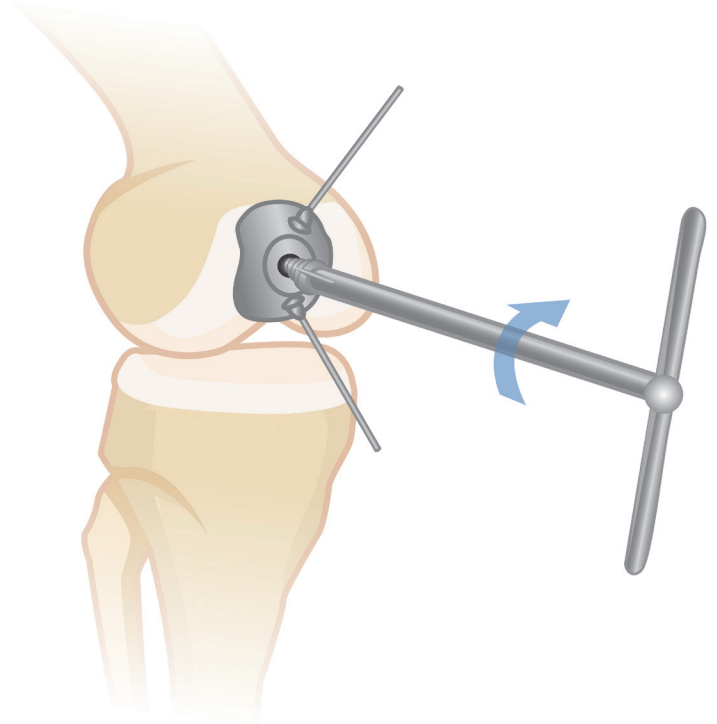
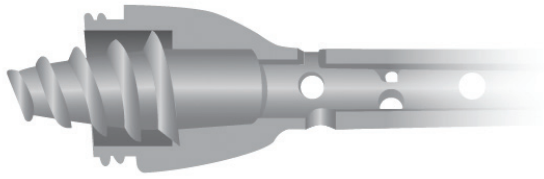

11. Apply a small amount of low-viscosity bone cement into the **Taper Post** tunnel. Place the **Taper Post** into the morse taper of the **Trial Handle** and attach to the **Sizing Trial**. Place the **Hex Driver** through the **Trial Handle** and advance the **Taper Post** until the stop on the shaft of the **Hex Driver** comes in contact with the back of the **Trial Handle**. Place the **Placement Gauge** into the **Sizing Trial** to ensure that the **Taper Post** is at proper depth to engage the **Femoral Component**.

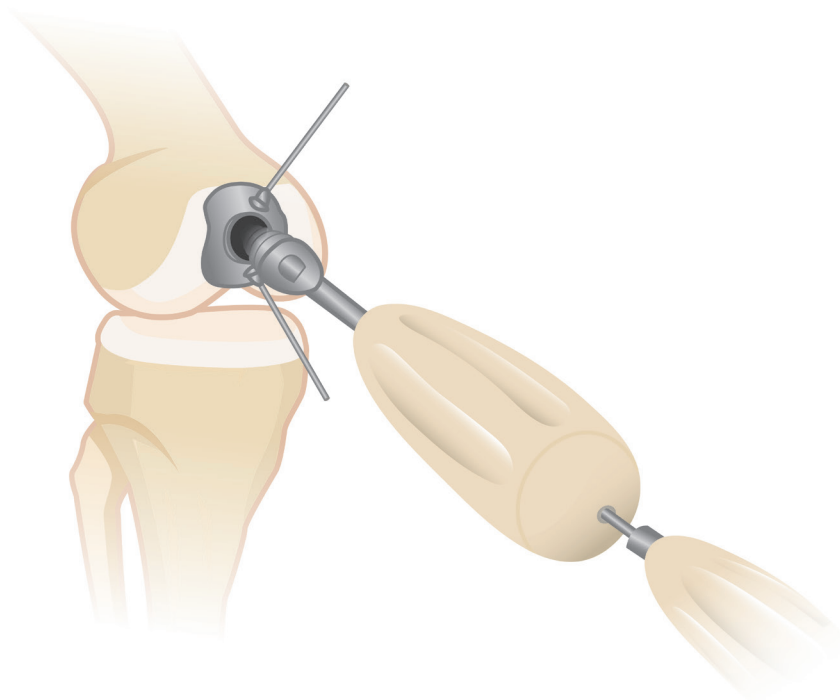

12. An alternative approach to fixation is to pre-assemble the **Threadless Stud** to the **Femoral Resurfacing Component**. Be sure to protect the articular face of the **Femoral Resurfacing Component** by using slight impaction with the mallet to seat the Morse taper of the **Threadless Stud** onto the **Femoral Resurfacing Component**.

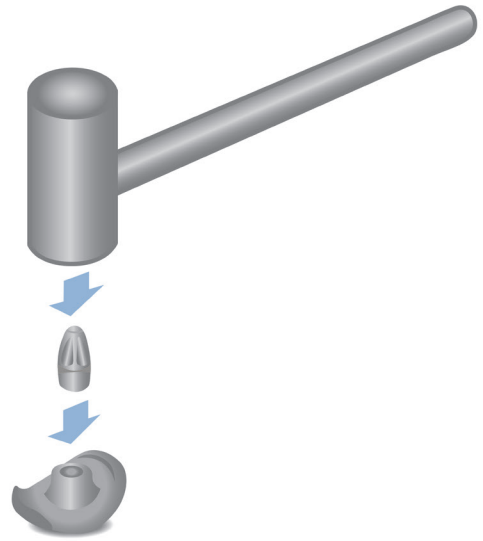

**NOTE:** Prepare and implant the **Patella Component** (p. 26) prior to the final placement of the **Femoral Trochlear Component**.

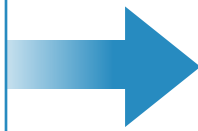

13. Prior to placing the **Femoral Component** on the **Implant Holder**, make sure that sufficient suction is present to hold the device on the distal suction cup. Align the **Femoral Component** on the **Implant Holder** with the medial etch mark facing the medial aspect of the knee and lateral mark facing the lateral plane. Insert into the taper of the **Taper Post**. Firmly mallet the **Impactor** until the **Femoral Component** is completely seated.

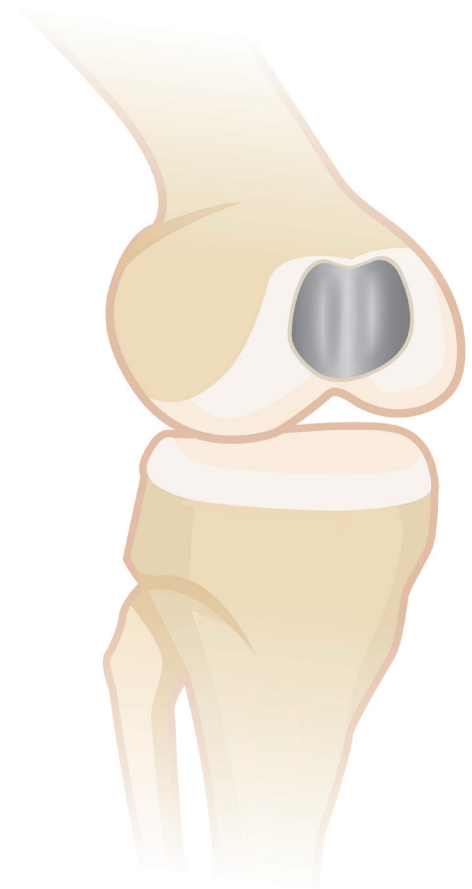
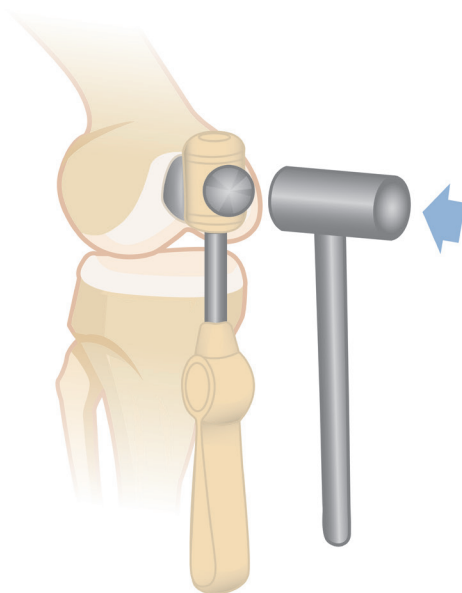

## Surgical Technique (PF Wave™ Patella Component)

1. With knee in extension, evert the patella and determine the **Patella Component** with the proper diameter by selecting the **Patella Reamer** or **Sizing Trial** that provides the most effective coverage.
2. Load the **2.5mm Guide Pin** into a Jacobs chuck and cannulated powered drill. Insert the **2.5mm Guide Pin** through the appropriate **Patella Sizing Trial** and locate the **Patella Sizing Trial** in an anterior position to develop a working axis normal to the patella surface. The **Patella Sizing Trial** acts as a guide for placing the **Guide Pin** appropriately. (Alternatively the **Patella Reamer** can be used to locate the **Guide Pin**.)
3. Holding the cannulated powered drill and **Patella Sizing Trial** perpendicular to the patella, drill the **Guide Pin** through the **Patella Sizing Trial** until it engages the opposite cortex of the patella. Leave the **Guide Pin** in place and remove the cannulated powered drill from the **Guide Pin**.
4. Load the **Patella Reamer** into the Jacobs chuck of the cannulated powered drill. Using the drill, advance the **Patella Reamer** over the **Guide Pin** until it reaches the depth indicator markings. The depth markings are located on the side of the **Patella Reamer** just superior to the cutting flutes.

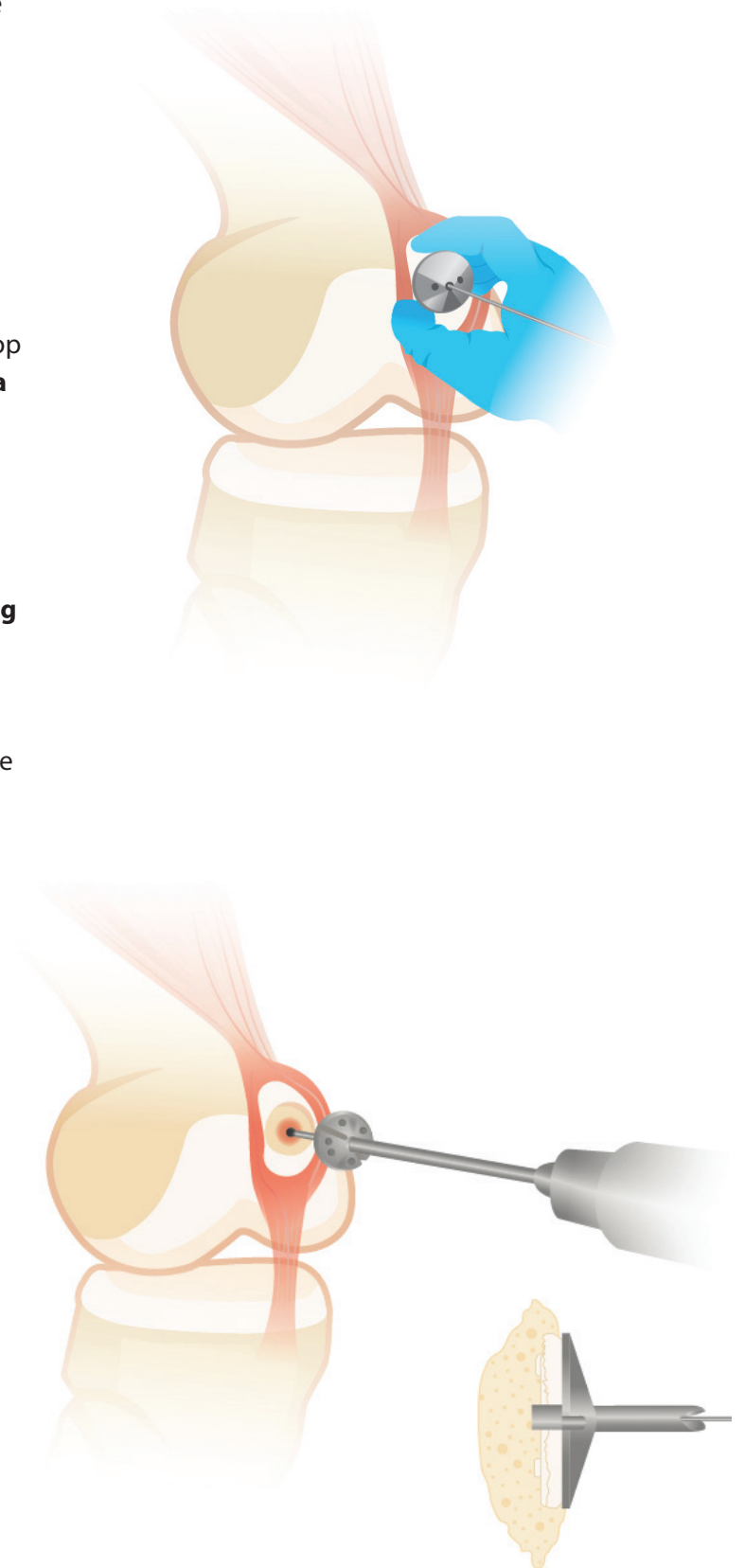

5. Load a loop of suture through the appropriately sized **Patella Sizing Trial** and place into the prepared area. Confirm the fit of the **Patella Sizing Trial** so that all margins are congruent or recessed to the edge of the surrounding articular surface.

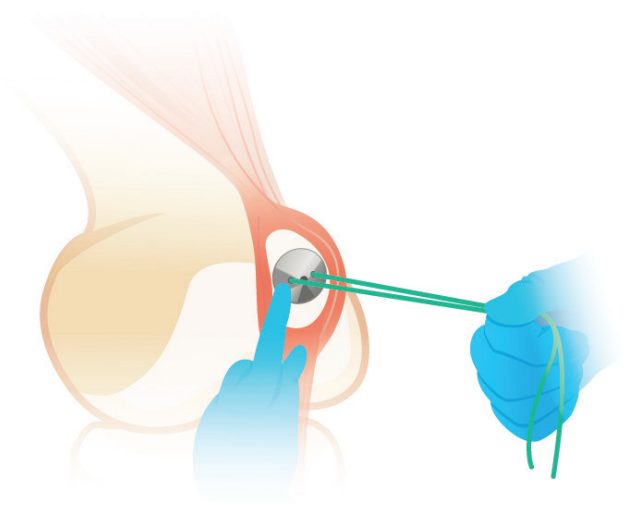

6. Reinsert the **Patella Reamer** and insert the **Guide Pin** into the cement channel holes in the patella bone. This will create a series of offset channels for cement fixation. Remove the **Guide Pin**.

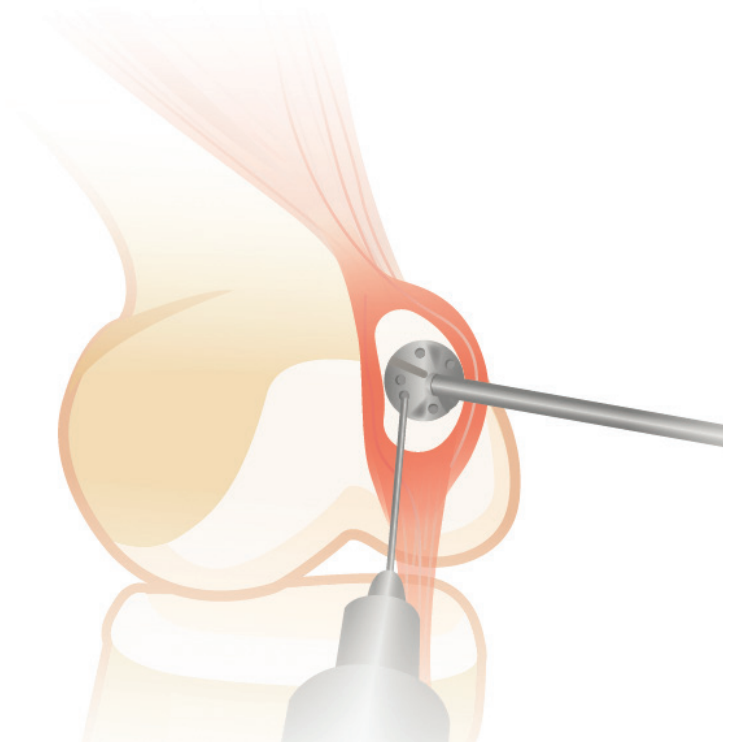

7. Confirm size and open the **Patella Component**.

*Note: When using the **Anatomic Patella Component**, make sure to align the superior and inferior orientation of the component with the superior and inferior poles of the patella.*

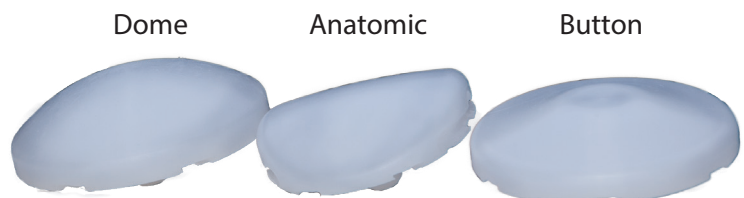



8. Apply a sufficient amount of low-viscosity bone cement into the reamed socket of the patella and quickly place the **Patella Component** into position.

9. Using the **Patella Clamp**, firmly press the **Patella Component** into the patella until the bone cement has sufficiently cured for proper fixation. Clean out any remaining exposed cement and debris.

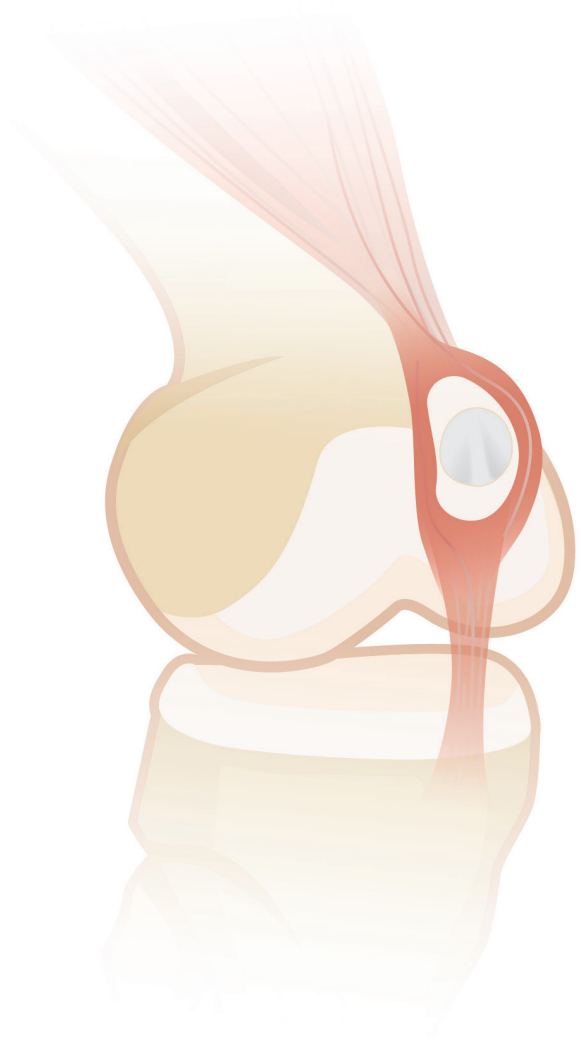

**NOTE:** Complete implantation of **Femoral Trochlear Component** (p. 25)

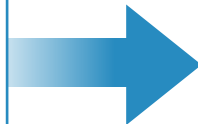

10. Once implantation of the **Femoral** and **Patella Components** is complete, perform a trial range of motion. Remove or debride any loose tissues if necessary. Remove all osteophytes. Close utilizing accepted practices.

# Sizing Cards (PF Wave™)

arthrosurface®  
Patello-Femoral WAVE  
Femoral Component

Sizing Card

- Average SI:  (+)
- Average ML:  (-)

2. Select HemiCAP® offset values

S/I	M/L
7.0 mm x 4.0 mm	7.0 mm x 5.0 mm
8.5 mm x 4.0 mm	8.5 mm x 5.0 mm
10.0 mm x 4.0 mm	10.0 mm x 5.0 mm
11.5 mm x 4.0 mm	11.5 mm x 5.0 mm

- Select Central Reamer size  
*Choose the Central Reamer that most closely matches the average ML (-) offset value.*
- Select Guide Block size  
*Choose Guide Block that most closely matches the average SI (+) offset value.*

## System Catalog

### Instrumentation System

7000-2300	Instrument Kit, Patello-Femoral Wave
7000-2302	Instrument Kit, 25/30mm Patella
PX07-1205	2.5mm Guide Pin, Wave (5 Pk) (non-sterile)
PX00-0200	2.5mm Guide Pin Kit, Wave (sterile)

### Articular Component, Patella

P255-1050	25mm Anatomic, 7.0mm thick
P306-0070	30mm Button, 7.0mm thick
P306-0090	30mm Dome, 9.0mm thick

### Taper Post

PX11-0218	Taper Post, 11mm x 21.5mm
-----------	---------------------------

### Fixation Stud

PX75-0173	Fixation Stud, 7.5mm x 18.5mm
-----------	-------------------------------

### Articular Component, Trochlear

		⊕ S/I	⊖ M/L
PX02-0704	7.0mm x 4.0mm Offset		
PX02-0705	7.0mm x 5.0mm Offset		
PX02-0854	8.5mm x 4.0mm Offset		
PX02-0855	8.5mm x 5.0mm Offset		
PX02-1004	10.0mm x 4.0mm Offset		
PX02-1005	10.0mm x 5.0mm Offset		
PX02-1154	11.5mm x 4.0mm Offset		
PX02-1155	11.5mm x 5.0mm Offset		

# Instrumentation (PF Wave)

## Upper Tray

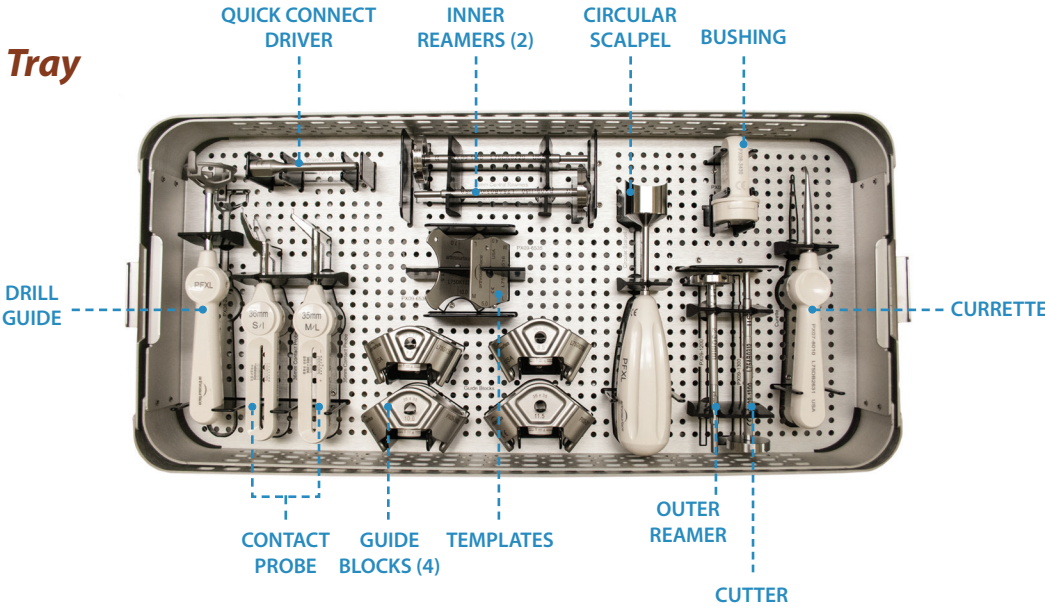

## Lower Tray

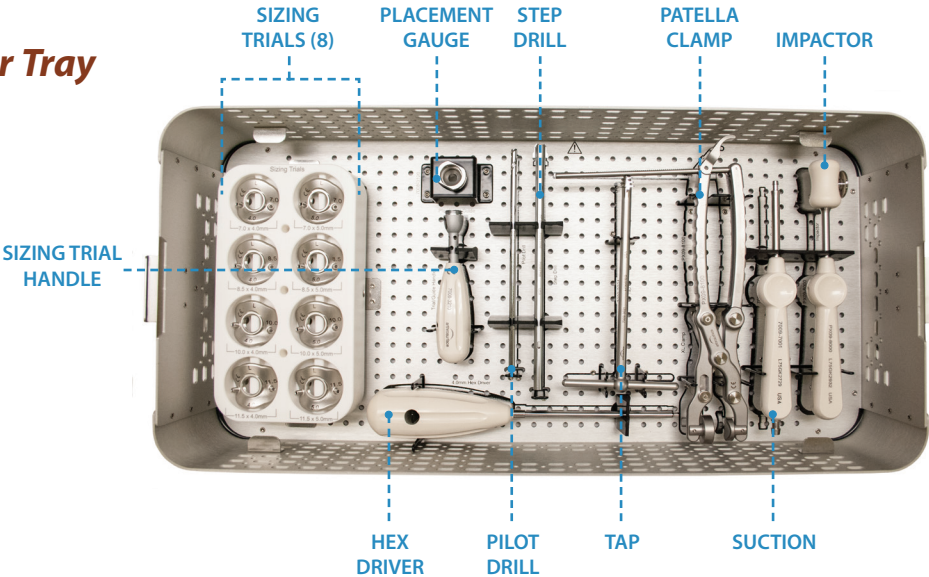

## Patella Caddy

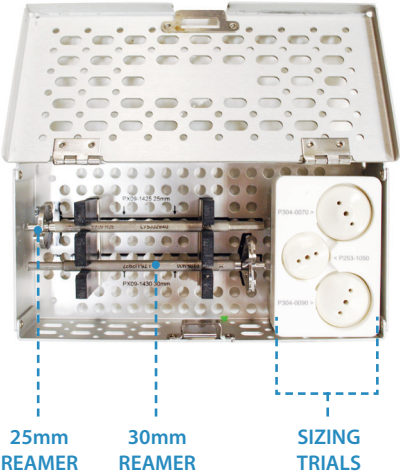



## Warnings

Improper selection, placement, positioning, alignment, and fixation of the implant components may reduce the service life of the prosthetic components. Inadequate preparation and cleaning of the implant components mating surfaces may result in improper fixation of the device. Improper handling of the implants can produce scratches, nicks or dents that may have adverse clinical effects on mating joint surfaces. Do not modify implants. The surgeon shall be thoroughly familiar with the implants, instruments, and surgical technique prior to performing surgery.

When defining offsets of articular surfaces, care should be taken to ensure that instruments are properly aligned and mated with taper in Taper Post. Visually confirm distal tip of contact probe is making contact on articular surfaces and free from any soft tissue structures to ensure accuracy. Use light pressure on contact probe to slightly indent articular surface at each offset point, ensuring that the selected implant will be flush or slightly recessed with the articular surface.

Prior to placing implant, carefully trim articular cartilage debris around prepared margin. Remove bone particles and lavage thoroughly. To ensure mechanical interlock of the Taper Post and implant, carefully clean Taper Post taper with provided instruments. All drilling or reaming should be done with vigorous lavage to minimize heat effects to adjacent bone and cartilage tissues.

Accepted practices in post operative care should be used. The patient is to be instructed and monitored to ensure a reasonable degree of compliance to post operative instructions and activity restrictions. Excessive activity, impact, and weight gain have been implicated in the reduction of the benefit and service life of prosthetic devices.

## Precautions

PF Wave™ implants are intended to be fitted and installed with the PF Wave™ instrument set. Use of instruments from other systems may result in improper implant selection, fitting, and placement which could result in implant failure or poor clinical outcome. The PF Wave™ instrument set should be regularly inspected for any signs of wear or damage. Do not reuse implants or disposable instruments.

## Possible Adverse Effects

- 1) Material sensitivity reactions. Implantation of foreign material in tissues can result in histological reactions. Particulate wear debris and mild tissue discoloration from metallic components have been noted in other prosthetic devices constructed of similar materials. Some types of wear debris have been associated with osteolysis and implant loosening.
- 2) Infection or allergic reaction.
- 3) Loosening, migration or loss of fixation of implant.
- 4) Fretting and crevice corrosion can occur at the interface between the implant components.
- 5) Fatigue fracture of the implants as a result of bone resorption around the implant components.
- 6) Wear and damage to the implant articulating surface.
- 7) Wear and damage to the adjacent and opposed articular cartilage surfaces or soft tissue support structures.
- 8) Intraoperative or postoperative bone fracture.

Wave<sup>™</sup> Kahuna<sup>™</sup>

Wave<sup>™</sup> Kahuna



**KEY FEATURES:**

*Minimal bone removal maintains future options*

*Multiple inlay trochlea and patella implants  
provide an anatomic articulation*

*Reproducible milling jigs for precise fit*

## Treatment Considerations for Patello-Femoral Arthroplasty

Patients with Patello-Femoral disease can be divided into two groups:

Group A: Patients with normal patello-femoral tracking and no dysplasia.

Group B: Patients with patello-femoral malalignment and / or trochlea dysplasia.

Group A patients can be treated with patello-femoral arthroplasty alone, whereas Group B patients require concomitant procedures to optimize tracking and outcomes.

### Supplementary Literature:

1. Cotic M, Forkel P, Imhoff AB (2017) [Patellofemoral arthroplasty]. Oper Orthop Traumatol 29:40-50
2. Cotic M, Imhoff AB (2014) [Patellofemoral arthroplasty: indication, technique and results]. Orthopade 43:898-904
3. Imhoff A, Beitzel K, Stamer K, Klein E (2014) Rehabilitation in der orthopädischen Chirurgie: OP-Verfahren im Überblick-Physiotherapie-Sporttherapie. Springer-Verlag
4. Imhoff AB, Feucht MJ, Meidinger G, Schottle PB, Cotic M (2015) Prospective evaluation of anatomic patello-femoral inlay resurfacing: clinical, radiographic, and sports-related results after 24 months. Knee Surg Sports Traumatol Arthrosc 23:1299-1307

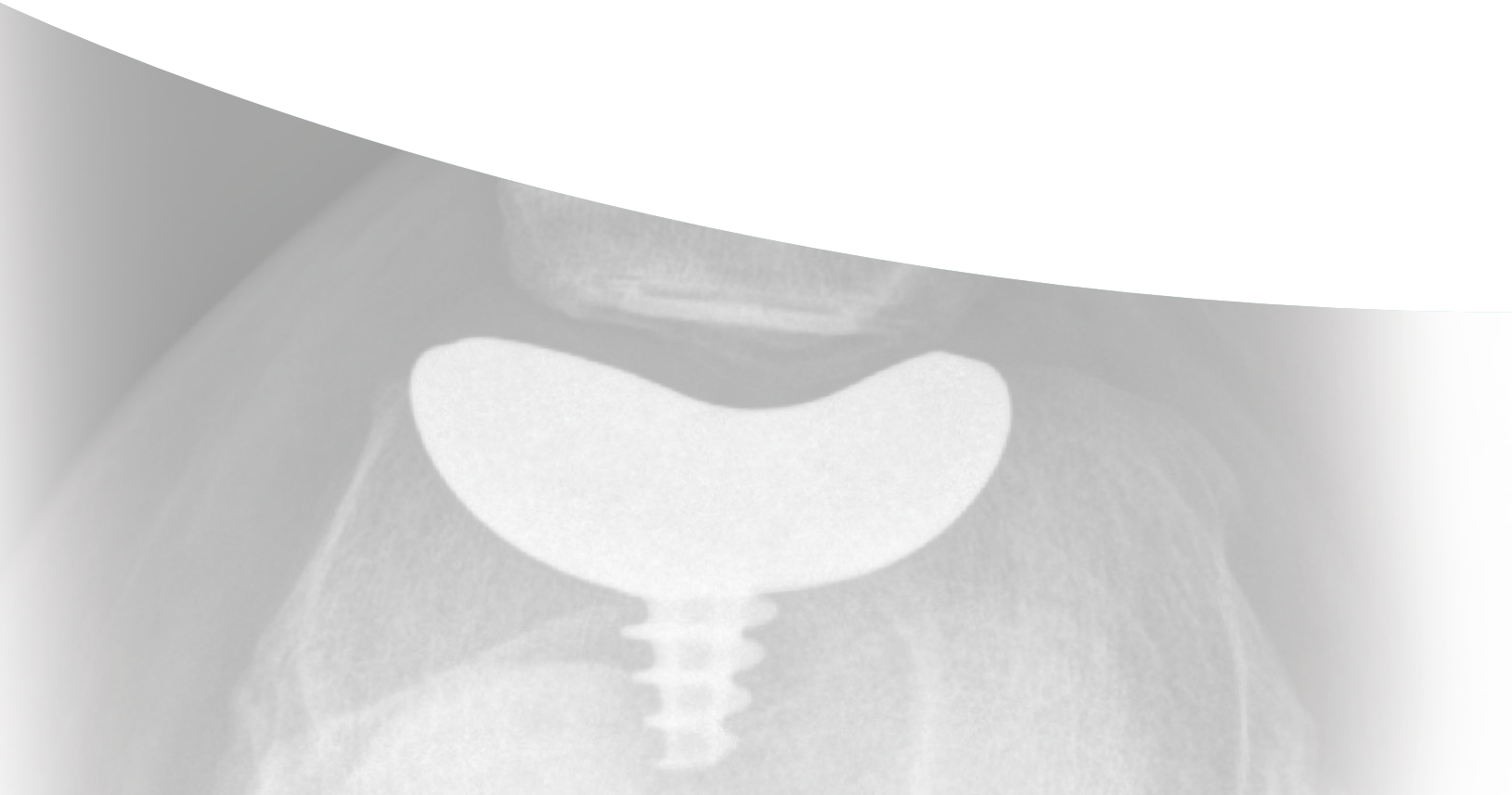

## Surgical Approaches for WaveKahuna™ Arthroplasty

- The surgical approach for patello-femoral arthroplasty is determined by several factors including surgeon preference, the patient's surgical history, and underlying pathology taking blood supply and stabilizing soft tissues into consideration.
- The patient is positioned in the supine position, with a tourniquet on the proximal thigh.
- The tourniquet is inflated and a longitudinal incision centered over the patella is made, extending from the quadriceps tendon down just medial of the tubercle.
- The subcutaneous tissue and superficial fascia are reflected over the patella medially by a blunt, sharp dissection. The fascia is divided and retracted, making sure to leave a cuff of tissue on the medial border of the patella for re-suture or advancement. The dissection is deep in between the vastus medialis muscle and the medial border of the quadriceps tendon and the capsule subsequently incised along the medial border of the patella and patellar tendon.
- As an alternative, a subvastus approach can be utilized. This approach preserves the vascularity of the patella as well as the quadriceps tendon and the VMO attachment. The same straight longitudinal incision is made, at which point the superficial fascia is incised slightly medial to the patella and bluntly dissected off of the vastus medialis muscle fascia, down to the muscle insertion. The inferior edge of the vastus medialis is identified and bluntly dissected off of the periosteum and intramuscular septum for a distance of 8-10 centimeters proximal to the adductor tubercle.
- The tendinous insertion of the muscle on the medial patellar retinaculum is identified and the vastus medialis muscle is lifted anteriorly.
- An L-shaped arthrotomy, beginning medially through the vastus insertion on the medial patellar retinaculum, is performed, carrying it along the medial edge of the patella, at which time the patella can be everted laterally. Upon completion of the procedure, perform a layered closure of biomechanically important structures according to accepted surgical technique.

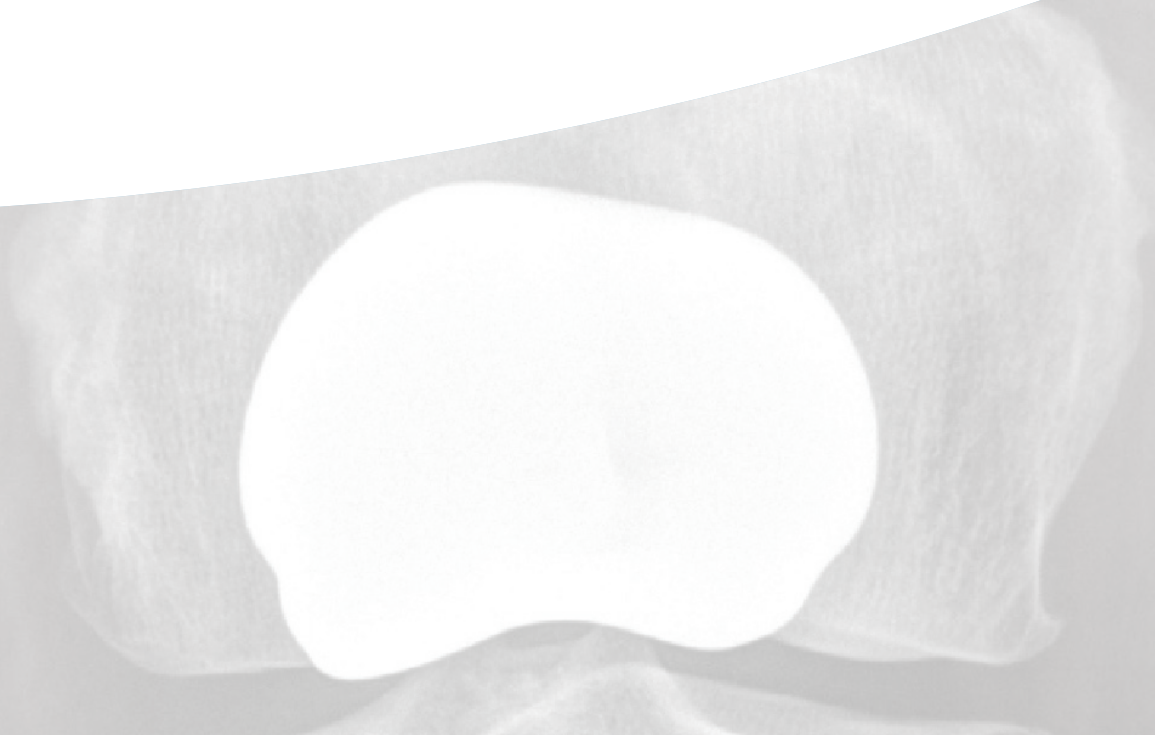

## Description

The **Patello-Femoral WaveKahuna™ Arthroplasty System** incorporates a distal femoral trochlear surface articular component that mates to a taper post via a taper interlock, and an all-polyethylene patella component. The prosthesis is intended to be used in cemented arthroplasty.

## Materials

Femoral Resurfacing Component:	Cobalt-Chromium Alloy (Co-Cr-Mo)
Surface Coating:	Titanium (CPTi)
Taper Post:	Titanium Alloy (Ti-6Al-4V)
Patella Component:	Ultra-High-Molecular Weight Polyethylene (UHMWPE)

## Indications

The Patello-Femoral WaveKahuna™ Arthroplasty System is intended to be used in cemented arthroplasty in patients with osteoarthritis limited to the distal patello-femoral joint, patients with a history of patellar dislocation or patellar fracture, and those patients with failed previous surgery (arthroscopy, tibial tubercle elevation, lateral release, etc.) where pain, deformity or dysfunction persists.

### Patient selection factors to be considered include:

- 1) Need to obtain pain relief and improve function
- 2) Patient's tibio-femoral joint is substantially normal
- 3) Patient exhibits no significant mechanical axis deformity
- 4) Patient's menisci and cruciates are intact with good joint stability, and good range of motion
- 5) Patient's overall well-being is good, including the ability and willingness to follow instructions and comply with activity restrictions

## Contraindications

### Absolute contraindications include:

- 1) Defects that are not localized
- 2) Inflammatory degenerative joint disease, rheumatoid arthritis, infection, sepsis, or osteomyelitis
- 3) Patients that have a known sensitivity to materials typically used in orthopedic prosthetic devices or bone cements

### Relative contraindications include:

- 1) Uncooperative patient or patient incapable of following pre-operative and post-operative instructions
- 2) Metabolic disorders, which may impair the formation or healing of bone; osteoporosis.
- 3) Infections at remote sites, which may spread to the implant site
- 4) Rapid joint destruction or bone resorption visible on roentgenogram
- 5) Chronic instability or deficient soft tissues and other support structures
- 6) Vascular or muscular insufficiency
- 7) Inadequate skin, musculotendinus or neurovascular system status

## Sterility

Metallic prosthetic components are sterilized by exposure to gamma irradiation. Non-metallic prosthetic components are sterilized by gas plasma sterilization. Do not resterilize any components. Do not use components if packaging is opened or damaged. Do not use components if beyond expiration date.



# Surgical Technique (WaveKahuna™ Femoral Component)

1. With knee in extension, use the **Mapping Template** to identify the S/I curvature of the trochlear groove.
- 2a. Select corresponding S/I curvature **Sizing Trial** and attach the **Femoral Pin Guide**. Place the **2.5mm Femoral Guide Pin** into a cannulated powered drill and advance **2.5mm Femoral Guide Pin** until secure in the bone (approximately 10mm deep).
- 2b. Alternatively, the **Offset Drill Guide** may be used to place the **2.5mm Femoral Guide Pin**. Align the "L" laser mark to the lateral aspect of the femur.

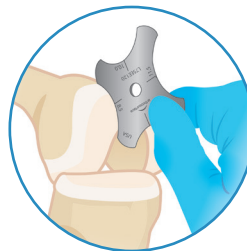

S/I Mapping Template

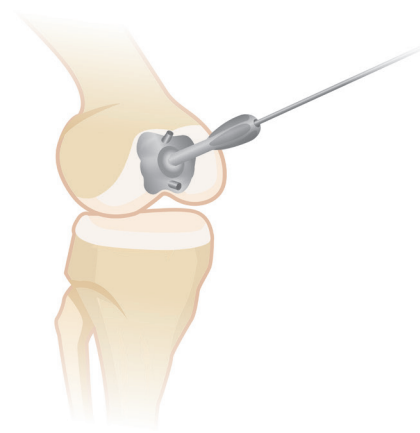

- i. Place the yellow **Offset Sleeve** over the **2.5mm Femoral Guide Pin** so the foot of the **Offset Sleeve** is touching the deepest (medial) portion at the center of the trochlea. Place the **Contact Probe** over the **Offset Sleeve** and use light pressure on the **Contact Probe** to ensure proper contact with the articular surface.
- ii. Read the **Contact Probe** to confirm superior/inferior offsets. Use the **Sizing Card** to record the average superior/inferior offset.

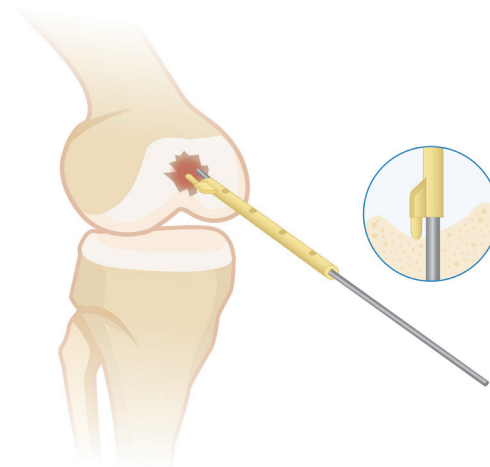

arthrosurface®  
Patello-Femoral WaveKahuna™  
Femoral Component

Sizing Card

1. Average SI: \_\_\_\_\_  
ML: 5 Only
2. Select HemiCAP® offset values
 

S/I	M/L
7.0 mm	5.0 mm
8.5 mm	5.0 mm
10.0 mm	5.0 mm
11.5 mm	5.0 mm
3. Use Central Reamer size 5.0
4. Select Guide Block size  
*Choose Guide Block that most closely matches the average SI offset value.*
5. Select Appropriate Right/Left Implant

PIN 2001-1136 Rev D

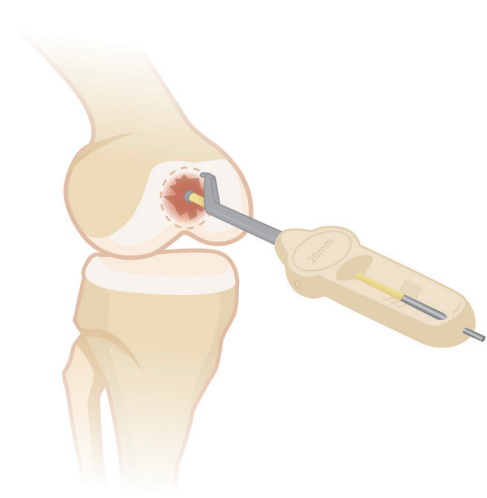

3. Select the **35mm Central Reamer (5mm)** and advance it over the **2.5mm Femoral Guide Pin** until the etched mark on the side of the **Central Reamer** is flush with the medial/lateral facets.

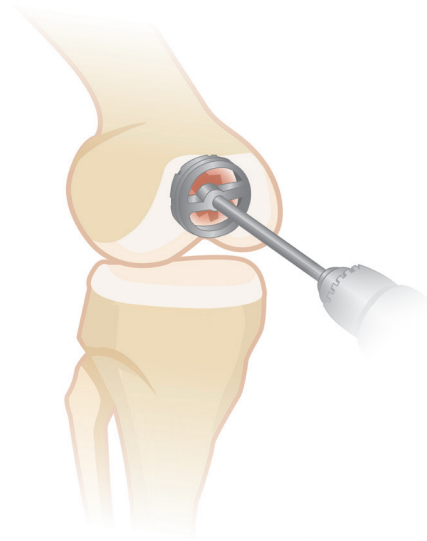

4. Select the **Guide Block** that corresponds with the S/I curvature value and place onto the trochlear groove. Insert the central portion of the **Guide Block** into the reamed area and secure the **Guide Block** onto the femur using the **2.0mm Guide Pins**.

In knees with a dysplastic or flattened trochlea, the **Guide Block** may not sit flush to the reamed area. Use an osteotome or burr to create slots in the bone to accept the proximal and distal feet of the **Guide Block**. Creating these slots will allow the **Guide Block** to sit flush to the reamed area.

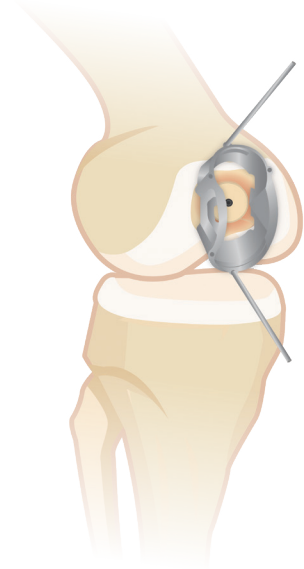

5. Assemble the **Outer Reamer** into the **Guide Bushing**. Secure the **Guide Bushing** into the inferior **Guide Block** bore. Advance the **Outer Reamer** into the bone until the depth mark on the reamer shaft is reached. Remove assembly and repeat reaming through the superior **Guide Block** bore. It is critical to keep the **Guide Block** stable during reaming. Repeat the same sequence for the cannulated **Kahuna Tooth Cutter**.

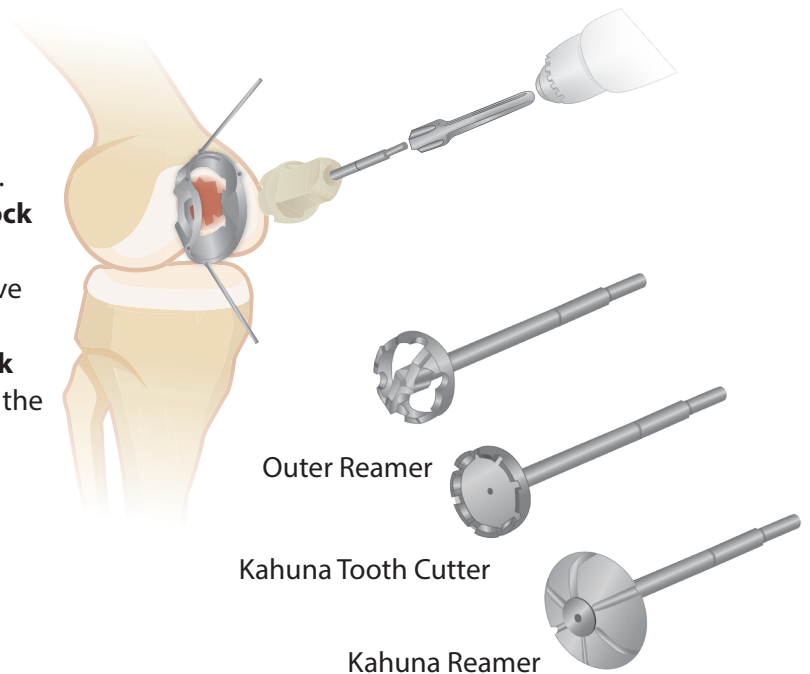

6. With the **Kahuna Tooth Cutter** in the **Guide Bushing** at the superior **Guide Block** bore position, drive the **2.5mm Femoral Guide Pin** into bone to create a stable working axis for the **Kahuna Reamer** (approximately 10mm deep).

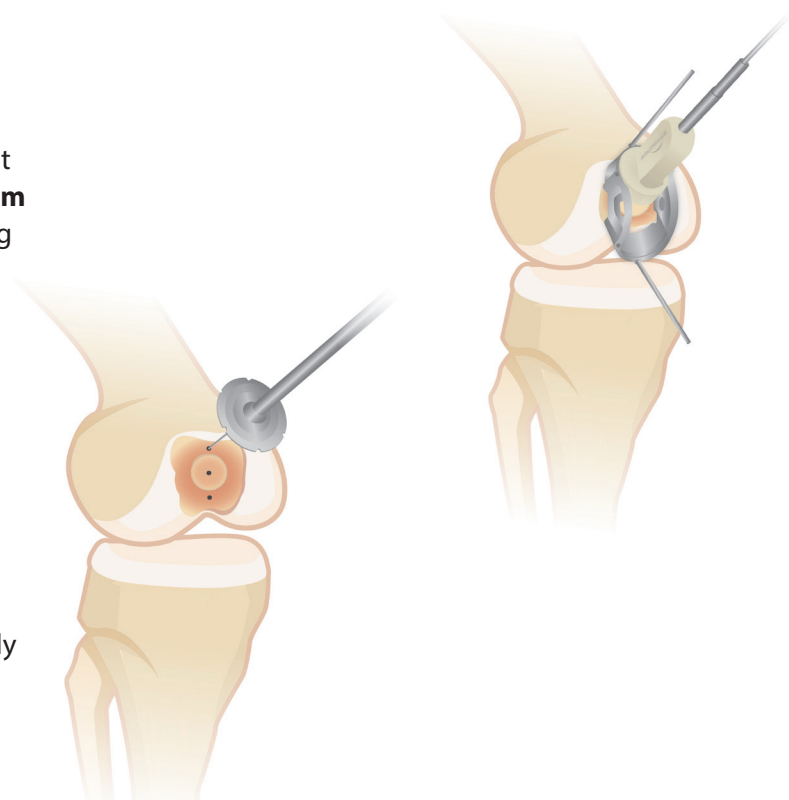

7. Remove the **Guide Block**. Ream over the **2.5mm Femoral Guide Pin** with the **Kahuna Reamer** until reamer bottoms out on the central part of the previously reamed surface.

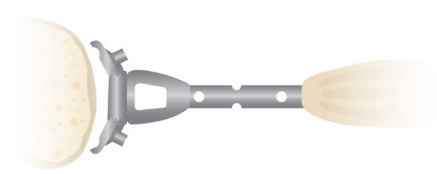

8. Assemble the **Trial Handle** onto the **Sizing Trial** that corresponds with the *S/I* curvature value. Place the **Sizing Trial** into the prepared site. Confirm the fit of the **Sizing Trial** so that all margins are congruent or recessed to the edge of the surrounding articular surface. Trim the transition areas between the reamed surfaces to ensure the **Sizing Trial** is fully seated. Fix the **Sizing Trial** in place using the **2.0mm Guide Pins**.

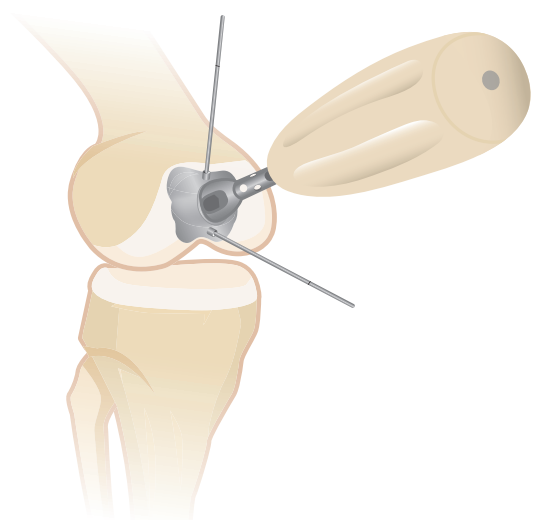

9. Insert the **Pilot Drill** through the center of the **Trial Handle** and advance to the laser mark indicated on the **Pilot Drill**. Leave the **Pilot Drill** in place and remove the **Trial Handle** from the **Sizing Trial**.

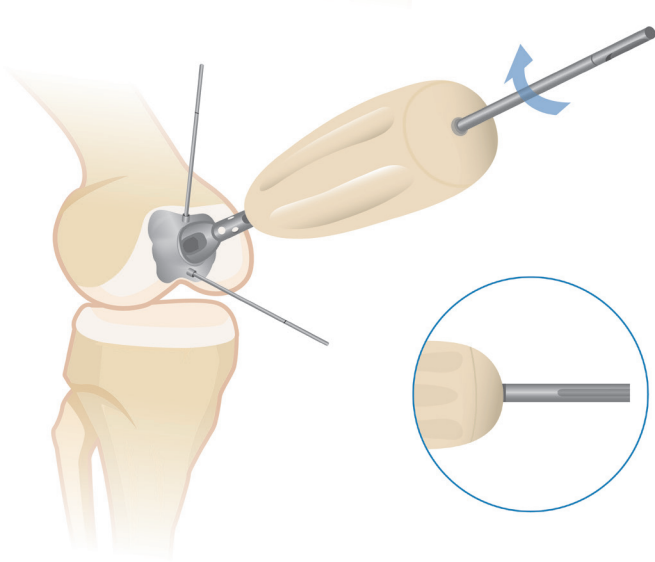

10. Advance the **Step Drill** over the **Pilot Drill** until it bottoms out on the back of the **Pilot Drill**. Remove the **Step Drill**.

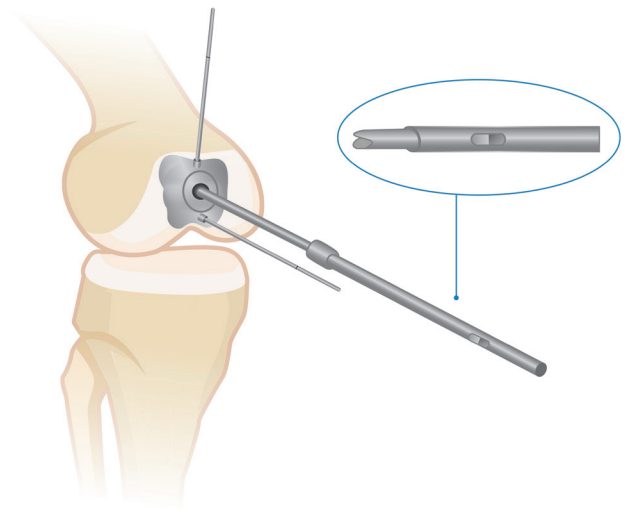

11. Advance the **Tap** over the **Pilot Drill** so the end stops when the **Pilot Drill** is flush to the back of the cannulation in the **Tap**. Remove the **Tap** and **Pilot Drill**.

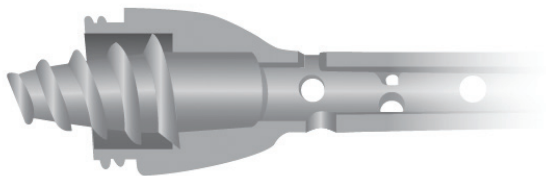
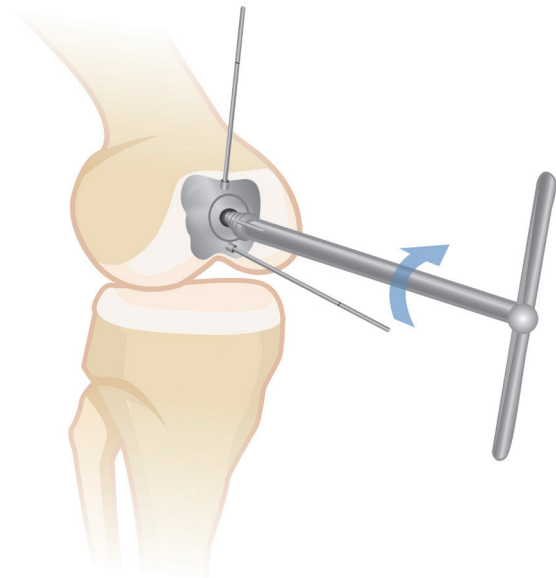

12. Apply a small amount of low-viscosity bone cement into the **Taper Post** bone tunnel. Place the **Taper Post** into the Morse taper of the **Trial Handle** and attach to the **Sizing Trial**. Place the **Hex Driver** through the **Trial Handle** and advance the **Taper Post** until the stop on the shaft of the **Hex Driver** comes in contact with the back of the **Trial Handle**. Place the **Placement Gauge** into the **Sizing Trial** to ensure that the **Taper Post** is at proper depth to engage the **WaveKahuna™ Femoral Component**.

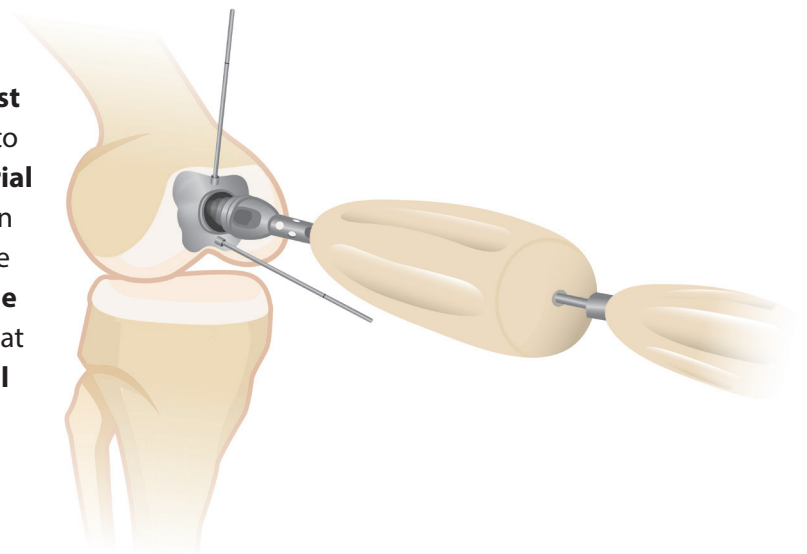

13. An alternative approach to fixation is to pre-assemble the **Threadless Stud** to the **WaveKahuna™ Femoral Component**. Be sure to protect the articular face of the **Kahuna™ Femoral Component** by using slight impaction with the mallet to seat the morse taper of the **Threadless Stud** onto the **Kahuna™ Femoral Component**.

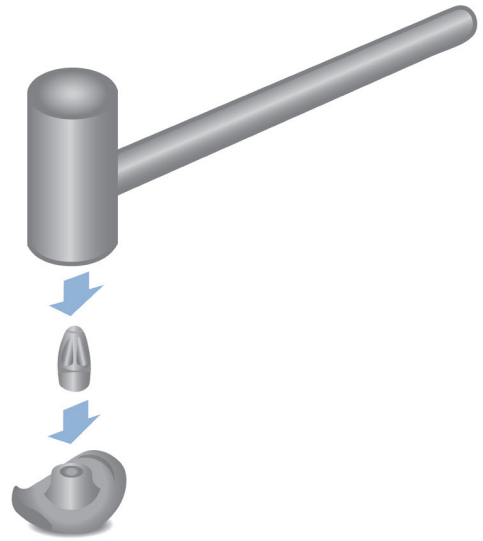

**NOTE:** Prepare the **Patella Component** implant site (p. 10) prior to the final placement of the **WaveKahuna™ Femoral Component**.

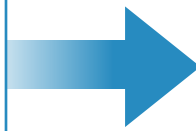

14. Prior to placing the **WaveKahuna™ Femoral Component** on the **Implant Holder**, make sure that sufficient suction is present to hold the device on the distal suction cup. Align the **WaveKahuna™ Femoral Component** on the **Implant Holder**. Insert into the taper of the **Taper Post**. Firmly mallet the **Impactor** until the **WaveKahuna™ Femoral Component** is completely seated.

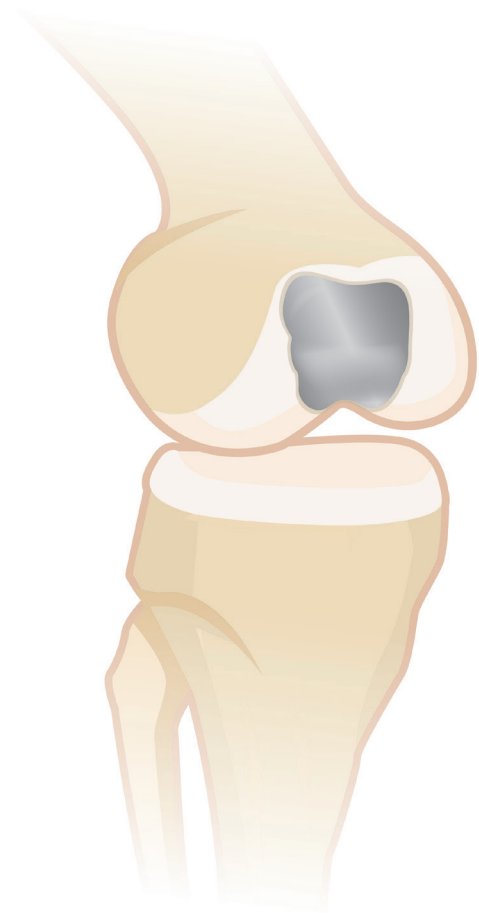
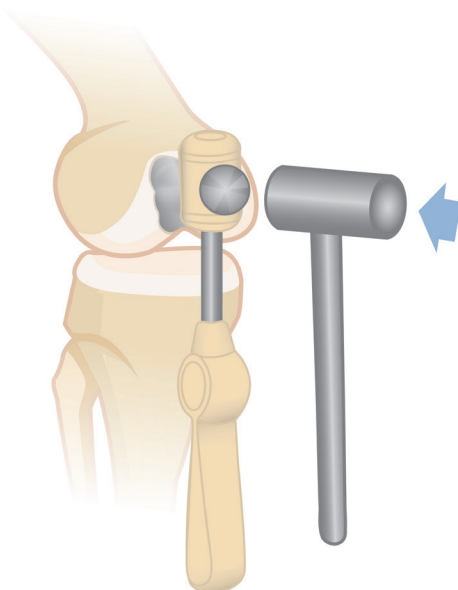

## Surgical Technique (Patella Component)

1. With knee in extension, evert the patella and determine the appropriate **Patella Component** diameter by utilizing the **Patella Sizing Trial** to evaluate the most effective coverage. Place the **Patella Pin Guide** onto the patella surface so the medial and lateral feet are in contact with the patella surface and the **Patella Pin Guide** is centered in the M/L and S/I planes. Drill the **Patella Guide Pin** through the patella until it engages the opposite cortex.
2. Leave the **Patella Guide Pin** in place and use the **Patella Depth Gauge** to measure patella thickness. Calculate the target reaming depth based on the **Patella Component** thickness as identified on the **Patella Component** box label.
3. Load the **Patella Reamer** into a cannulated powered drill. Using the drill, advance the **Patella Reamer** over the **Patella Guide Pin** until the calculated target reaming depth has been reached. Confirm the reaming depth using the **Patella Depth Gauge**.

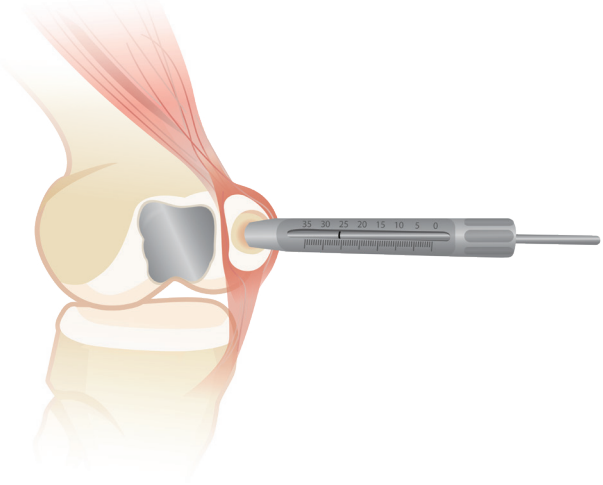
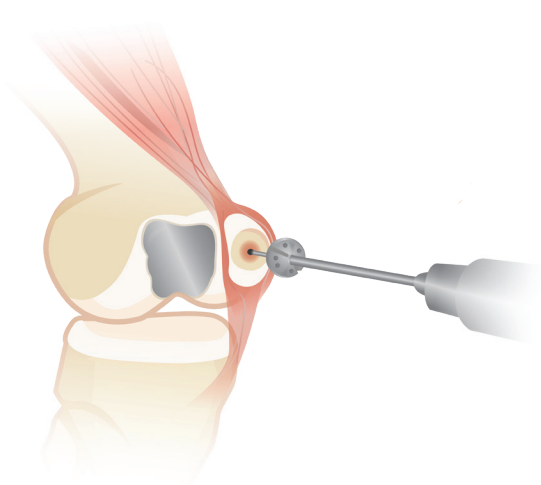
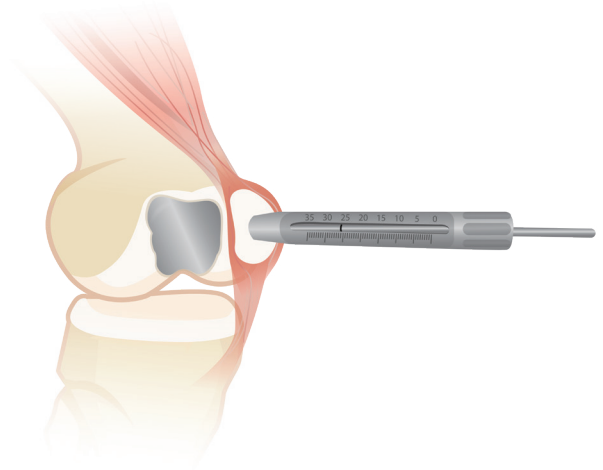
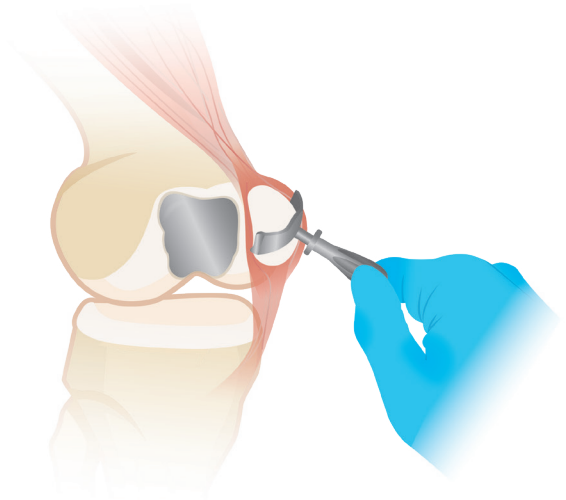

4. Load a loop of suture through the corresponding **Patella Sizing Trial** and place into the prepared area. Carefully orient the medial and lateral features of the **Sizing Trial**. The dimple feature on the articular surface of the **Patella Component** is intended to be placed laterally. Confirm the fit of the **Patella Sizing Trial** so that all margins are congruent or recessed to the edge of the surrounding articular surface. Using the **Femoral Reduction Trial**, perform reduction and trial range of motion. Remove or debride any loose tissues if necessary. Remove all osteophytes and confirm PF tracking.

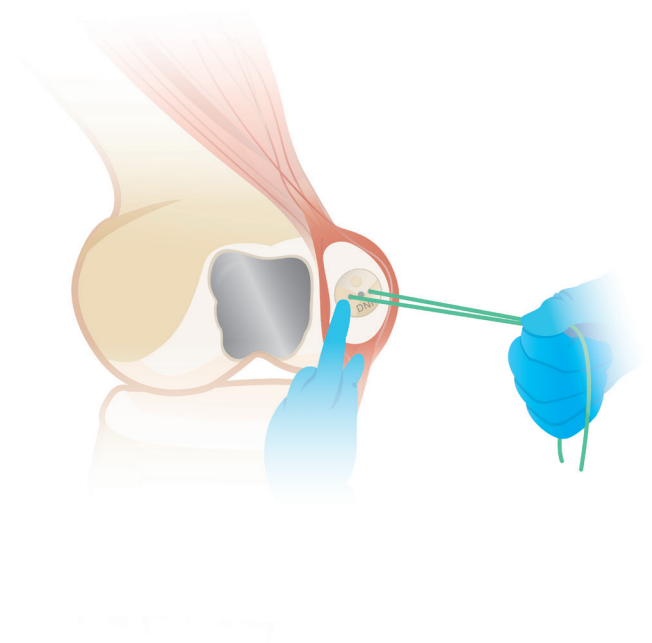

5. Confirm size, open the **Patella Component** and carefully orient medial and lateral features of implant. Apply a sufficient amount of low-viscosity bone cement into the reamed socket of the patella and quickly place the **Patella Component** into position ensuring correct placement of the medial and lateral features of the implant. The dimple feature on the articular surface of the **Patella Component** is intended to be placed laterally.

Locate Laterally

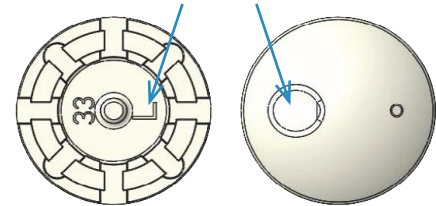

6. Using the **Patella Clamp**, firmly press the **Patella Component** into the patella until the bone cement has sufficiently cured for proper fixation. Clean out any remaining exposed cement and debris.

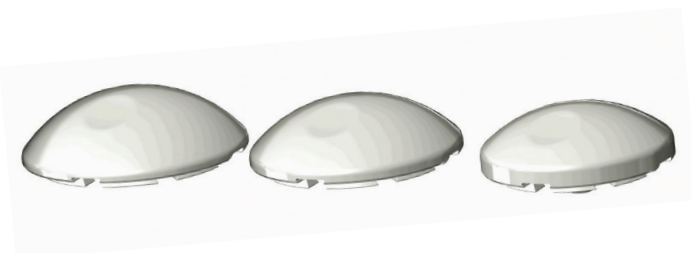
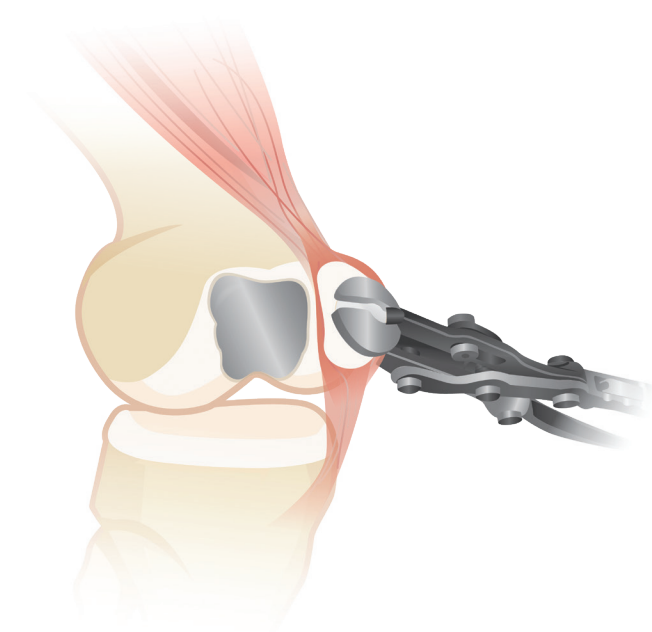

7. Complete implantation of appropriate Left/Right **WaveKahuna™ Femoral Component** (p. 9).



8. Once implantation of the **WaveKahuna™ Femoral** and **Patella Components** is complete, ensure no bone cement is left in joint. Remove or debride any loose tissues if necessary. Remove all osteophytes. Close utilizing accepted practices.

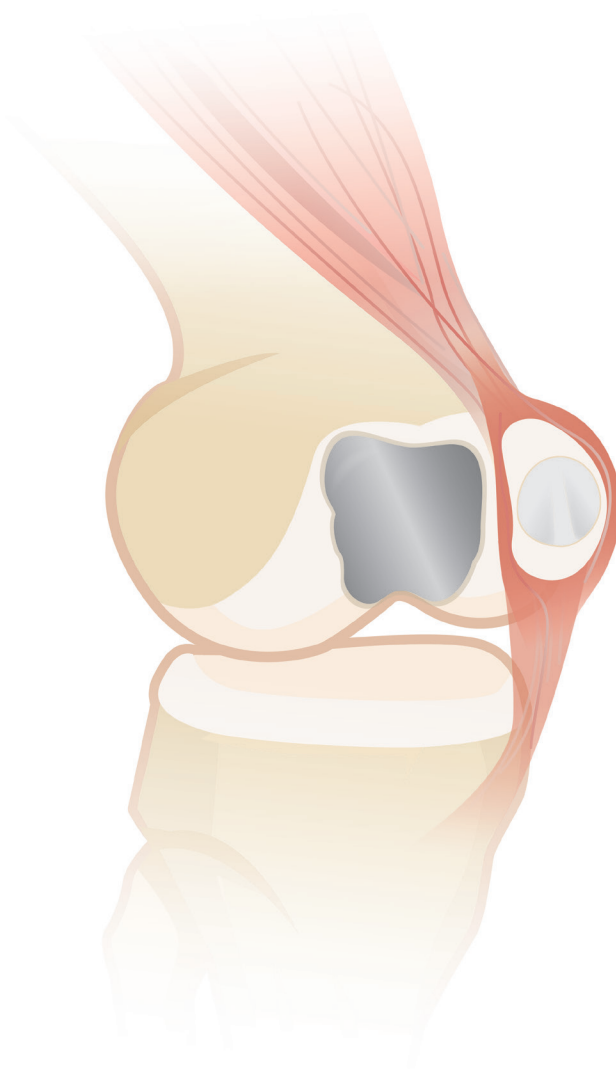



# Sizing Card (WaveKahuna)

arthrosurface®  
Patello-Femoral Wave<sup>Kahuna</sup>™  
Femoral Component

S

I

Sizing Card

1. Average SI: \_\_\_\_\_  
ML: 5 Only
2. Select HemiCAP® offset values
 

S/I	M/L
7.0 mm	5.0 mm
8.5 mm	5.0 mm
10.0 mm	5.0 mm
11.5 mm	5.0 mm
3. Use Central Reamer size 5.0
4. Select Guide Block size  
*Choose Guide Block that most closely matches the average SI offset value.*
5. Select Appropriate Right/Left Implant

P/N 2001-1136 Rev D

## System Catalog

### Instrumentation System

7000-2300	Instrument Kit, Patello-Femoral Wave
7000-2400	Instrument Kit, WaveKahuna
7000-2302	Instrument Kit, 25/30mm Patella
PX00-0200	Guide Pin Kit, Femoral (sterile)
PW07-1000	Guide Pin Kit, Patella (sterile)

### Articular Component, Patella

P306-K090	30mm Dome
P336-K095	33mm Dome
P356-K105	35mm Dome

### Taper Post

PX11-0218	Taper Post, 11mm x 21.5mm
-----------	---------------------------

### Articular Component, Femoral

#### Left

PWL2-0705	7.0mm Offset, Left
PWL2-0855	8.5mm Offset, Left
PWL2-1005	10.0mm Offset, Left
PWL2-1155	11.5mm Offset, Left

#### Right

PWR2-0705	7.0mm Offset, Right
PWR2-0855	8.5mm Offset, Right
PWR2-1005	10.0mm Offset, Right
PWR2-1155	11.5mm Offset, Right

### Fixation Stud

PX75-0173	Fixation Stud, 7.5mm x 18.5mm
-----------	-------------------------------

# Instrumentation

## PF Wave™

### Upper Tray

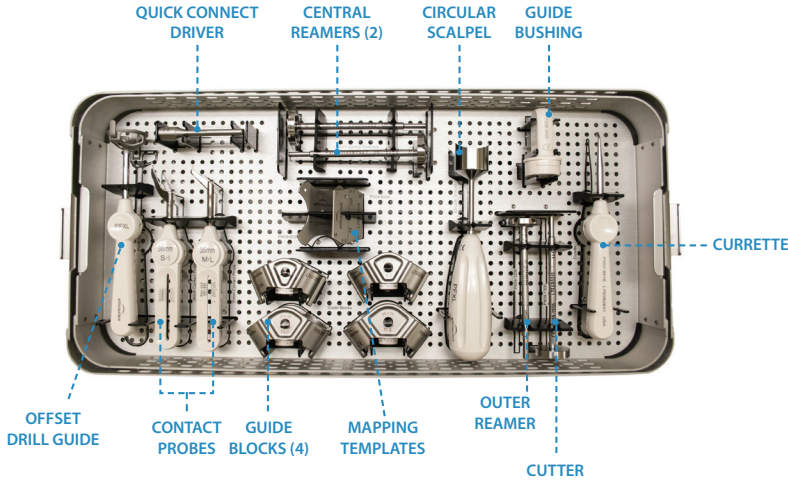

### Patella Tray

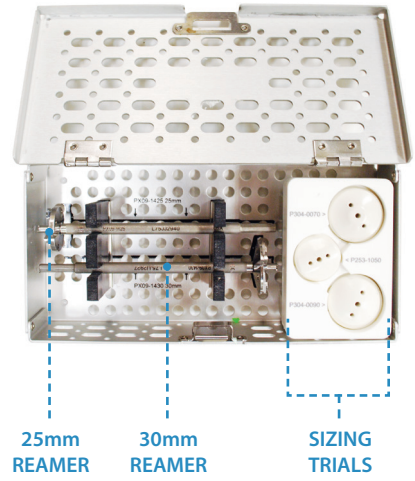

### Lower Tray

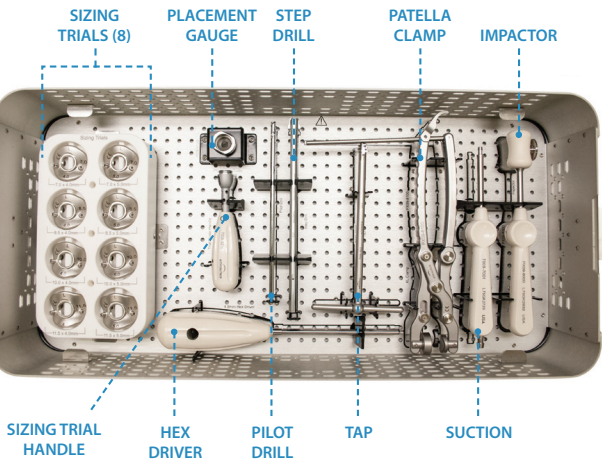

## WaveKahuna™

### Kahuna Tray

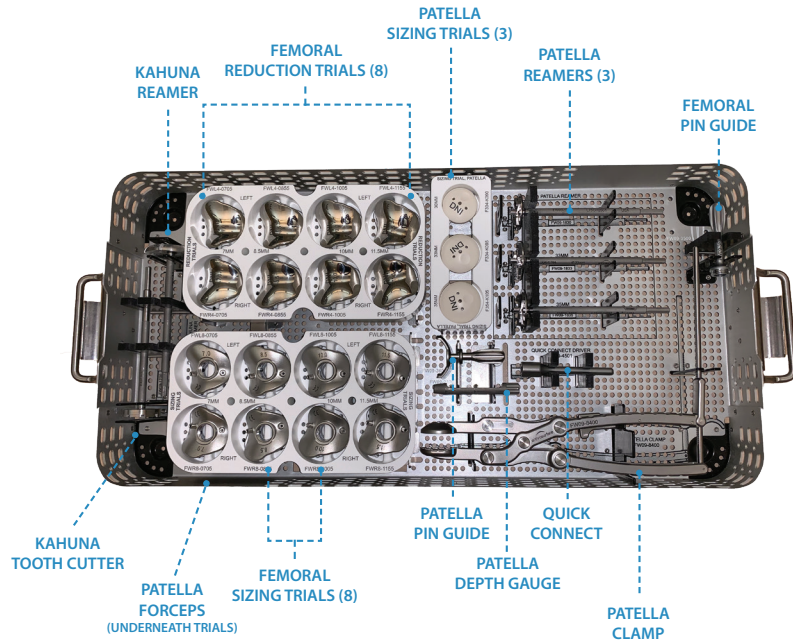

## Warnings

Improper selection, placement, positioning, alignment, and fixation of the implant components may reduce the service life of the prosthetic components. Inadequate preparation and cleaning of the implant components mating surfaces may result in improper fixation of the device. Improper handling of the implants can produce scratches, nicks or dents that may have adverse clinical effects on mating joint surfaces. Do not modify implants. The surgeon shall be thoroughly familiar with the implants, instruments, and surgical technique prior to performing surgery.

When defining offsets of articular surfaces, care should be taken to ensure that instruments are properly aligned and mated with taper in Taper Post. Visually confirm distal tip of contact probe is making contact on articular surfaces and free from any soft tissue structures to ensure accuracy. Use light pressure on contact probe to slightly indent articular surface at each offset point, ensuring that the selected implant will be flush or slightly recessed with the articular surface.

Prior to placing implant, carefully trim articular cartilage debris around prepared margin. Remove bone particles and lavage thoroughly. To ensure mechanical interlock of the Taper Post and implant, carefully clean Taper Post taper with provided instruments. All drilling or reaming should be done with vigorous lavage to minimize heat effects to adjacent bone and cartilage tissues. Ensure that care is taken to obtain complete and uniform bone cement coverage at implant site. Unsupported components or unevenly supported components may result in implant failure.

Accepted practices in post operative care should be used. The patient is to be instructed and monitored to ensure a reasonable degree of compliance to post operative instructions and activity restrictions. Excessive activity, impact, and weight gain have been implicated in the reduction of the benefit and service life of prosthetic devices.

Wave<sup>Kahuna</sup> implants have not been evaluated for safety and compatibility in the MR environment. They have not been tested for heating, migration, or image artifact in the MR environment. The safety of Wave<sup>Kahuna</sup> knee implants in the MR environment is unknown. Scanning a patient who has this device may result in patient injury.

## Precautions

Patello-Femoral implants are intended to be fitted and installed with the Patello-Femoral Arthroplasty instrument

set. Use of instruments from other systems may result in improper implant selection, fitting, and placement which could result in implant failure or poor clinical outcome. The instrument set should be regularly inspected for any signs of wear or damage. Do not reuse implants or disposable instruments. Reuse of single use devices can increase the risk of patient infection and can compromise service life and other performance attributes of the device.

## Possible Adverse Effects

- 1) Material sensitivity reactions. Implantation of foreign material in tissues can result in histological reactions. Particulate wear debris and mild tissue discoloration from metallic components have been noted in other prosthetic devices constructed of similar materials. Some types of wear debris have been associated with osteolysis and implant loosening.
- 2) Infection or allergic reaction.
- 3) Loosening, migration or loss of fixation of implant.
- 4) Fretting and crevice corrosion can occur at the interface between the implant components.
- 5) Fatigue fracture of the implants as a result of bone resorption around the implant components.
- 6) Wear and damage to the implant articulating surface.
- 7) Wear and damage to the adjacent and opposed articular cartilage surfaces or soft tissue support structures.
- 8) Intraoperative or postoperative bone fracture.
- 9) Postoperative pain or incomplete resolution of preoperative symptoms.
- 10) Periarticular calcification or ossification, with or without impediment of joint mobility.
- 11) Incomplete range of motion due to improper selection or positioning of components.
- 12) Transient nerve palsy.

## Caution

United States Federal law restricts this device to sale by or on the order of a physician.

## Patello-Femoral Inlay Arthroplasty Systems

### HemiCAP® PF Classic *13 Different Sizes & Convexities*



*Anatomic*

*Button*

### PF Wave™ *8 Different Sizes & Convexities*



*Dome*

*Button*



*Anatomic*

### WaveKahuna™ *8 Different Sizes & Convexities (4 Left & 4 Right)*



*Dome*



*Dome*



*Dome*

This product is covered by one or more of U.S. Patent Nos. 6,520,964; 6,610,067; 6,679,917 and other patents pending.

HemiCAP® is a trademark of Arthrosurface, Inc. U.S.

© 2019 Arthrosurface, Inc. All rights reserved.

Printed in U.S.A.

For more information:

[www.arthrosurface.com](http://www.arthrosurface.com)



28 Forge Parkway • Franklin, MA 02038  
P: 1 508 520 3003 • F: 1 508 528 3785  
[contact@arthrosurface.com](mailto:contact@arthrosurface.com)



This pamphlet and information is intended for markets where regulatory approval has been granted.